



PCI-104 Qseven Carrier Board

Connect Tech's PCI-104 Qseven Carrier Board is a small embedded carrier board that allows complete integration with any industry standard Qseven module. This carrier board, which utilizes the PC/104 form factor and the PCI-104 bus, allows installation of up to 4 PCI-104 boards. The on-board connectors enable connection to SATA, USB, Ethernet, LVDS Video, VGA Video, and RS-232 & RS-422/485. Easily upgrade to the latest processor and memory technology while maintaining the I/O interfaces.

What is Qseven?

Qseven is a Computer-on-Module standard for mobile and embedded applications. To learn more about Connect Tech's PCI-104 Qseven Carrier Board, visit <http://www.connecttech.com/Qseven>.

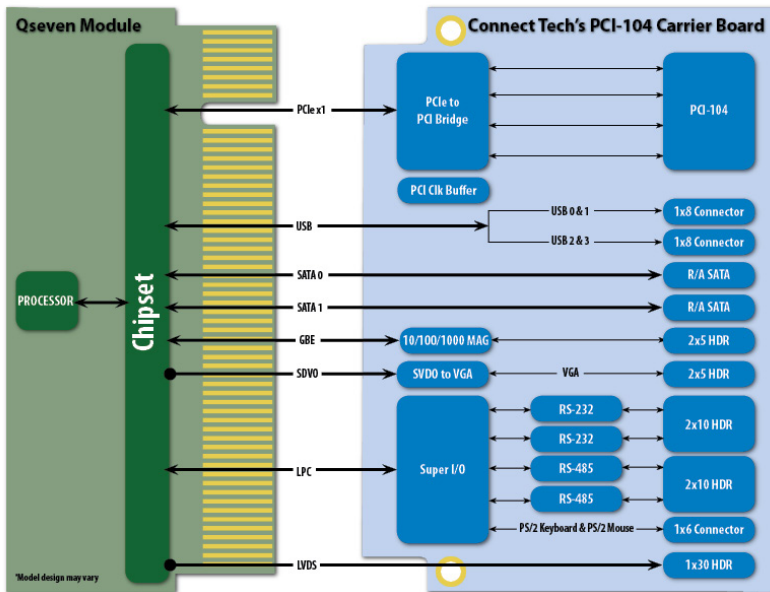

Product Name: PCI-104 Qseven Carrier Board
Part Number: QCG002

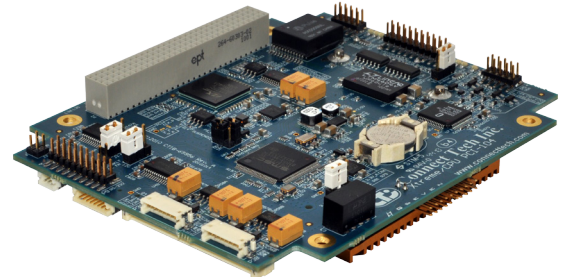

Note: Qseven module mounted on bottom. Qseven module sold separately.



FEATURES

- ✓ PCI-104 form factor
- ✓ Install up to 4 PCI-104 boards
- ✓ Uses any off-the-shelf Qseven module
- ✓ Ideal for applications with low power requirements
- ✓ Connectors and cables included for easy connection to Qseven features

Custom Design Services

Can't find the feature you need or require a different form factor?

The PCI-104 Qseven Carrier Board allows you to prototype your application, while Connect Tech's design services creates a custom solution.

Connect Tech Inc.

42 Arrow Road, Guelph ON Canada
Tel: 519.836.1291 **Fax:** 519.836.4878
Toll: 800.426.8979 (North America)
Email: sales@connecttech.com
www.connecttech.com

Specifications

Form Factor	PCI-104, allows installation of up to 4 PCI-104 boards
Display	VGA, LVDS flat panel
Storage	2x SATA
Serial Interface	2x RS-232, 2x RS-485
USB	4x USB 2.0
Ethernet	1x Gigabit Ethernet
Dimensions	PC/104 compliant
Temperature	-20°C to 70°C (-4°F to 158°F)
Power	ATX supply input
Power Consumption	To be determined
Additional I/O	PS/2 keyboard and mouse
Accessories	Optional Cable Kit
Warranty and Support	2 Year Warranty and free technical support



Specifications subject to change without notice.
 ©2015, Connect Tech Inc. All trademarks are property of their respective holder.