

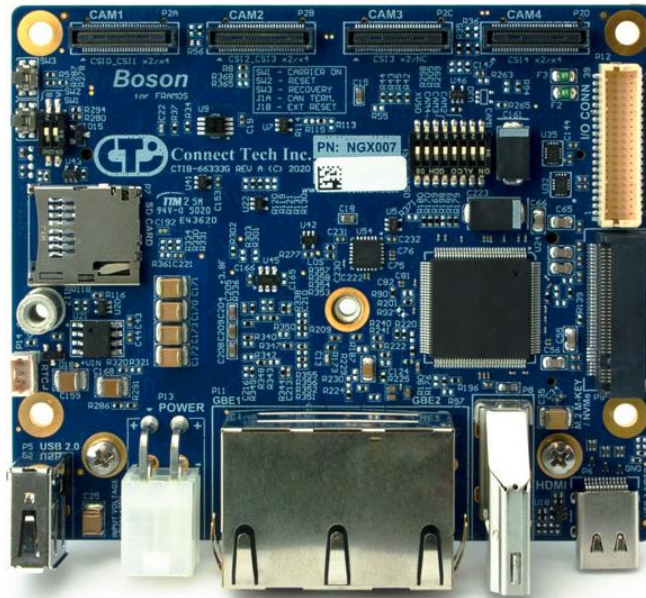

Connect Tech Inc.
Embedded Computing Experts

USERS GUIDE



Boson for FRAMOS

CTIM-00057 Revision 0.06 2024-02-14



CONNECT TECH
www.connecttech.com
support@connecttech.com

TABLE OF CONTENTS

Table of Contents	2
Preface	4
Disclaimer	4
Customer Support Overview	4
Contact Information	4
Limited Product Warranty.....	5
Copyright Notice	5
Trademark Acknowledgment	5
ESD Warning	6
Revision History	6
Introduction	7
Product Features and Specifications.....	8
Part Numbers / Ordering Information	9
Product Overview	10
Block Diagram	10
Connector and Switch Locations.....	11
Top side	11
Bottom side.....	12
Connector Summary.....	13
Switch and Jumper Summary.....	14
Detailed Feature Description	15
NVIDIA® Jetson Xavier™ NX / Jetson TX2™ NX/ Jetson Nano™ and Module Connector	15
FAN Connector	16
HDMI Connector.....	16
FRAMOS MIPI CSIx4 Connectors.....	17
FRAMOS MIPI CSIx2 Connector	18
Camera I/O Connectors	19
USB 3.1 w/OTG Gen 1 / 2 Type-C Connector.....	20
10/100/1000 Dual Ethernet Connector	20
M.2 M-key 2280 NVMe Connector	21
M.2 E-key 2230 Wi-Fi/BT Connector.....	21
USB 2.0 Type-A Connector	21
microSD Card Connector	22
Misc. I/O Connector	22
Power Connector	24
RTC Battery Connector.....	24
Reset Pushbutton	25
Force Recovery Pushbutton.....	25
Carrier Power ON – no module.....	25
Camera XVS0 and XHS0 DIP switch	26
Jumper for CAN termination and External Reset.....	26
Typical Installation	27
Power Consumption & Thermals	28
NVIDIA® Jetson Nano™	28

NVIDIA® Jetson Xavier™ NX.....	28
Current Consumption Details	28
Software / BSP Details	29
Cables (Not Included)	29
Accessories	29
Recommended Cameras	30

PREFACE

Disclaimer

The information contained within this user’s guide, including but not limited to any product specification, is subject to change without notice.

Connect Tech assumes no liability for any damages incurred directly or indirectly from any technical or typographical errors or omissions contained herein or for discrepancies between the product and the user’s guide.

Customer Support Overview

If you experience difficulties after reading the manual and/or using the product, contact the Connect Tech reseller from which you purchased the product. In most cases the reseller can help you with product installation and difficulties.

In the event that the reseller is unable to resolve your problem, our highly qualified support staff can assist you. Our support section is available 24 hours a day, 7 days a week on our website at: <https://connecttech.com/support/resource-center/>. See the contact information section below for more information on how to contact us directly. Our technical support is always free.

Contact Information

Contact Information	
Mail/Courier	Connect Tech Inc. Technical Support 489 Clair Road West Guelph, Ontario Canada N1L 0H7
Contact Information	sales@connecttech.com support@connecttech.com www.connecttech.com Toll Free: 800-426-8979 (North America only) Telephone: +1-519-836-1291 Facsimile: 519-836-4878 (on-line 24 hours)
Support	Please go to the Connect Tech Resource Center for product manuals, installation guides, device drivers, BSPs and technical tips. Submit your technical support questions to our support engineers. Technical Support representatives are available Monday through Friday, from 8:30 a.m. to 5:00 p.m. Eastern Standard Time.

Limited Product Warranty

Connect Tech Inc. provides a 1-year Warranty for this product. Should this product, in Connect Tech Inc.'s opinion, fail to be in good working order during the warranty period, Connect Tech Inc. will, at its option, repair or replace this product at no charge, provided that the product has not been subjected to abuse, misuse, accident, disaster or non-Connect Tech Inc. authorized modification or repair.

You may obtain warranty service by delivering this product to an authorized Connect Tech Inc. business partner or to Connect Tech Inc. along with proof of purchase. Product returned to Connect Tech Inc. must be pre-authorized by Connect Tech Inc. with an RMA (Return Material Authorization) number marked on the outside of the package and sent prepaid, insured and packaged for safe shipment. Connect Tech Inc. will return this product by prepaid ground shipment service.

The Connect Tech Inc. Limited Warranty is only valid over the serviceable life of the product. This is defined as the period during which all components are available. Should the product prove to be irreparable, Connect Tech Inc. reserves the right to substitute an equivalent product if available or to retract the Warranty if no replacement is available.

The above warranty is the only warranty authorized by Connect Tech Inc. Under no circumstances will Connect Tech Inc. be liable in any way for any damages, including any lost profits, lost savings or other incidental or consequential damages arising out of the use of, or inability to use, such product.

Copyright Notice

The information contained in this document is subject to change without notice. Connect Tech Inc. shall not be liable for errors contained herein or for incidental consequential damages in connection with the furnishing, performance, or use of this material. This document contains proprietary information that is protected by copyright. All rights are reserved. No part of this document may be photocopied, reproduced, or translated to another language without the prior written consent of Connect Tech, Inc.

Copyright © 2024 by Connect Tech, Inc.

Trademark Acknowledgment

Connect Tech, Inc. acknowledges all trademarks, registered trademarks and/or copyrights referred to in this document as the property of their respective owners. Not listing all possible trademarks or copyright acknowledgments does not constitute a lack of acknowledgment to the rightful owners of the trademarks and copyrights mentioned in this document.

ESD Warning



Electronic components and circuits are sensitive to ElectroStatic Discharge (ESD). When handling any circuit board assemblies including Connect Tech COM Express carrier assemblies, it is recommended that ESD safety precautions be observed. ESD safe best practices include, but are not limited to:

- Leaving circuit boards in their antistatic packaging until they are ready to be installed.
- Using a grounded wrist strap when handling circuit boards, at a minimum you should touch a grounded metal object to dissipate any static charge that may be present on you.
- Only handling circuit boards in ESD safe areas, which may include ESD floor and table mats, wrist strap stations and ESD safe lab coats.
- Avoiding handling circuit boards in carpeted areas.
- Try to handle the board by the edges, avoiding contact with components.

REVISION HISTORY

Revision	Date	Changes
0.00	2021-04-06	Preliminary Release
0.01	2021-09-09	Edited cable information; corrected pinout on MISC I/O connector (P12)
0.02	2021-09-20	Edited cable information, removed memory specification, updated USB specs
0.03	2022-05-01	<ol style="list-style-type: none"> 1. List of TX2™ NX integrations added 2. Camera I/O connector information added 3. Fixed pinout for P2A, P2B and P2C 4. CBG509 added for Camera I/O 5. S1 DIP switch information added for camera synchronization
0.04	2023-05-09	Addition of alternative parts version “NGX017”
0.05	2023-06-30	Added RTC battery connector pinout to picture
0.06	2024-02-14	Updated GPIO information

INTRODUCTION

Boson for FRAMOS is an AI vision powerhouse, integrating up to four MIPI cameras within an extremely small footprint. Specifically designed for use within the FRAMOS Sensor Ecosystem, Boson maximizes sensor inputs and storage solutions for high-end vision applications. This joint product offering provides customers with a plug and play vision solution that accelerates application development time. Compatible with the Jetson Nano™, TX2™ NX and Xavier™ NX SoMs, users can seamlessly transition between modules should their processing needs change.

Boson for FRAMOS comes standard with software hooks in the board support package that automatically connects select cameras in the FRAMOS Sensor Module Ecosystem to NVIDIA®'s JetPack SDK, eradicating any further development requirements from your Software team.

Boson for FRAMOS has four FRAMOS PixelMate connectors directly on the carrier board. These connectors allow users to directly connect up to 4x 2-lane or 3x 4-lane MIPI CSI-2 cameras from the FRAMOS Sensor Module Ecosystem.

While Boson for FRAMOS is compatible with NVIDIA® Jetson Nano™, TX2™ NX, and Xavier™ NX SoMs, some I/O availability will change across modules. View the [Boson for FRAMOS Compatibility Specifications](#) for a full breakdown.

Product Features and Specifications

These specifications are based on the **NVIDIA® Jetson Xavier NX**.

Feature	Boson for FRAMOS
Module Compatibility	NVIDIA® Jetson Xavier™ NX / Jetson TX2™ NX / Jetson Nano™
Ethernet^[1]	2x 1000 BASE-T Ethernet Port <ul style="list-style-type: none"> 1x Port sourced directly from NVIDIA® Jetson™ module 1x Port sourced from i210
MIPI Camera	Supports up to the following camera configurations: <ul style="list-style-type: none"> 3x 4-lane MIPI FRAMOS Sensor Modules 4x 2-lane MIPI FRAMOS Sensor Modules 2x 4-lane and 2x 2-lane MIPI FRAMOS Sensor Modules
Display Output	1x HDMI 2.0
Storage	1x NVMe M.2 M-Key 2280 (4-lane PCIe) 1x Micro SD Card
Wireless Expansion^[1]	1x WiFi/Bluetooth M.2 E-Key 2230 module
USB^[1]	1x USB 3.1 Gen 2 w/ OTG capability (Type C) 1x USB 2.0 (Type A)
Input Power / Misc Power Details	+9V to +36V Input Voltage Range <ul style="list-style-type: none"> Auto-ON operation by default
RTC Battery	1x RTC Battery External Connector
Fan	1x FAN w/ PWM Control
Operating Temperature	-40°C to +85°C (-40°F to +185°F)
Dimensions	90mm x 75mm (3.54" x 2.95")
Warranty and Support	1 Year Warranty and Free Support
Misc. I/O^[1]	3x 3.3V TTL UARTs (1x CONSOLE) 8x GPIOs 3.3V TTL (2x PWM Capable) 2x I2C 3.3V 1x CAN 2.0b 2x SPI 2x 3.3V 2x 5V 8x GND

[1] Please review the [Boson for FRAMOS Compatibility Specifications](#) for a full breakdown of feature differences between the NVIDIA® Jetson Xavier™ NX, NVIDIA® Jetson TX2™ NX and NVIDIA® Jetson Nano™ SoMs.

Part Numbers / Ordering Information

Part Number				
NGX007	Boson for FRAMOS Carrier Board			
NGX017	Boson for FRAMOS Carrier Board – Alternative Parts Version Note: The Below integrations can be purchased with an NGX017-## SKU as well.			
Integrated Assemblies				
Part Number	Module Option	Thermal Option	Storage Option	Wireless Option
NGX007-01	Jetson Nano™	Thermal Transfer Plate	No SSDs Installed	No Wireless Installed
NGX007-02	Jetson Nano™	Passive Heatsink	No SSDs Installed	No Wireless Installed
NGX007-03	Jetson Nano™	Active Heatsink	No SSDs Installed	No Wireless Installed
NGX007-04	Jetson Nano™	Thermal Transfer Plate	NVMe Installed	No Wireless Installed
NGX007-05	Jetson Nano™	Active Heatsink	NVMe Installed	No Wireless Installed
NGX007-06	Jetson Nano™	Passive Heatsink	NVMe Installed	No Wireless Installed
NGX007-07	Jetson Xavier™ NX	Thermal Transfer Plate	No SSDs Installed	No Wireless Installed
NGX007-08	Jetson Xavier™ NX	Passive Heatsink	No SSDs Installed	No Wireless Installed
NGX007-09	Jetson Xavier™ NX	Active Heatsink	No SSDs Installed	No Wireless Installed
NGX007-10	Jetson Xavier™ NX	Thermal Transfer Plate	NVMe Installed	No Wireless Installed
NGX007-11	Jetson Xavier™ NX	Passive Heatsink	NVMe Installed	No Wireless Installed
NGX007-12	Jetson Xavier™ NX	Active Heatsink	NVMe Installed	No Wireless Installed
NGX007-13	Jetson Xavier™ NX	Thermal Transfer Plate	No SSDs Installed	WiFi/Bluetooth Installed
NGX007-14	Jetson Xavier™ NX	Passive Heatsink	No SSDs Installed	WiFi/Bluetooth Installed
NGX007-15	Jetson Xavier™ NX	Active Heatsink	No SSDs Installed	WiFi/Bluetooth Installed
NGX007-16	Jetson Xavier™ NX	Thermal Transfer Plate	NVMe Installed	WiFi/Bluetooth Installed
NGX007-17	Jetson Xavier™ NX	Passive Heatsink	NVMe Installed	WiFi/Bluetooth Installed
NGX007-18	Jetson Xavier™ NX	Active Heatsink	NVMe Installed	WiFi/Bluetooth Installed
NGX007-19	Jetson Xavier™ NX	NVIDIA® Active Heatsink	No SSDs Installed	No Wireless Installed
NGX007-20	Jetson Xavier™ NX	NVIDIA® Active Heatsink	NVMe Installed	No Wireless Installed
NGX007-21	Jetson Xavier™ NX	NVIDIA® Active Heatsink	No SSDs Installed	WiFi/Bluetooth Installed
NGX007-22	Jetson Xavier™ NX	NVIDIA® Active Heatsink	NVMe Installed	WiFi/Bluetooth Installed
NGX007-23	Jetson TX2™ NX	Thermal Transfer Plate	No SSDs Installed	No Wireless Installed
NGX007-24	Jetson TX2™ NX	Passive Heatsink	No SSDs Installed	No Wireless Installed
NGX007-25	Jetson TX2™ NX	Active Heatsink	No SSDs Installed	No Wireless Installed

NGX007-26	Jetson TX2™ NX	Thermal Transfer Plate	NVMe Installed	No Wireless Installed
NGX007-27	Jetson TX2™ NX	Passive Heatsink	NVMe Installed	No Wireless Installed
NGX007-28	Jetson TX2™ NX	Active Heatsink	NVMe Installed	No Wireless Installed
NGX007-29	Jetson TX2™ NX	Thermal Transfer Plate	No SSDs Installed	WiFi/Bluetooth Installed
NGX007-30	Jetson TX2™ NX	Passive Heatsink	No SSDs Installed	WiFi/Bluetooth Installed
NGX007-31	Jetson TX2™ NX	Active Heatsink	No SSDs Installed	WiFi/Bluetooth Installed
NGX007-32	Jetson TX2™ NX	Thermal Transfer Plate	NVMe Installed	WiFi/Bluetooth Installed
NGX007-33	Jetson TX2™ NX	Passive Heatsink	NVMe Installed	WiFi/Bluetooth Installed
NGX007-34	Jetson TX2™ NX	Active Heatsink	NVMe Installed	WiFi/Bluetooth Installed

PRODUCT OVERVIEW

Block Diagram

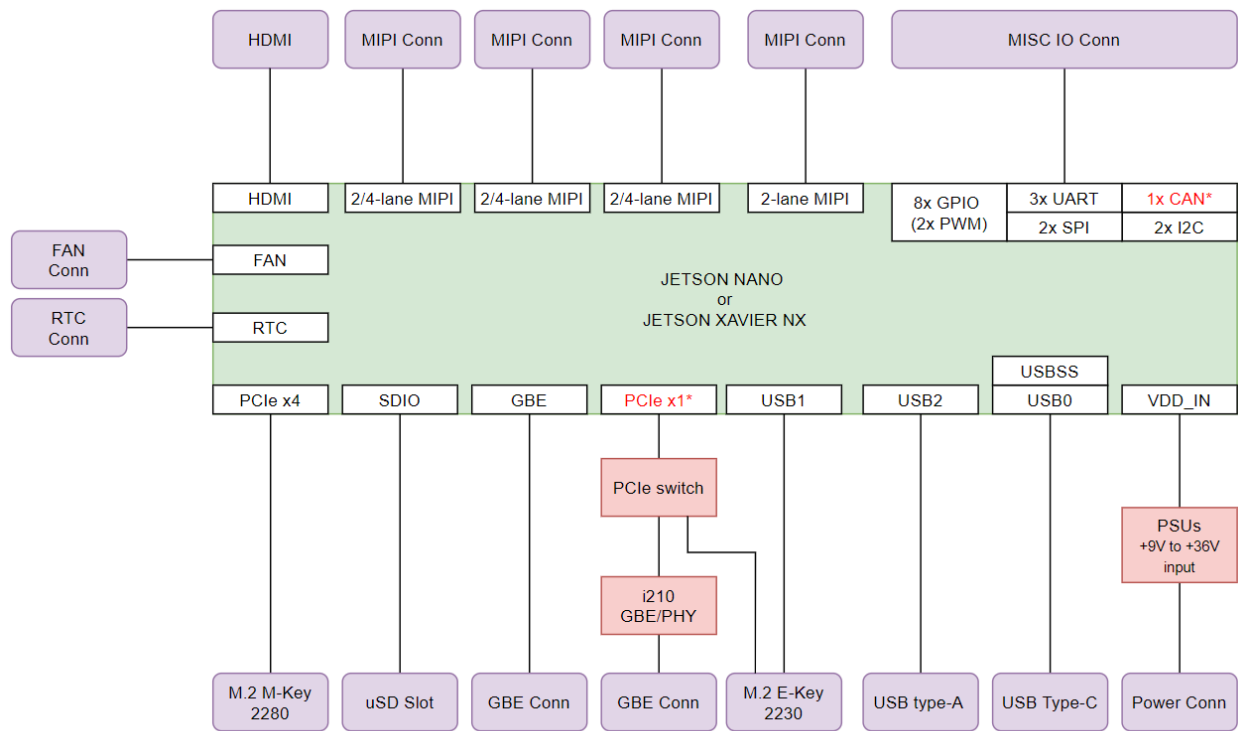

* Not Available on Nano Module

Connector and Switch Locations

Top side

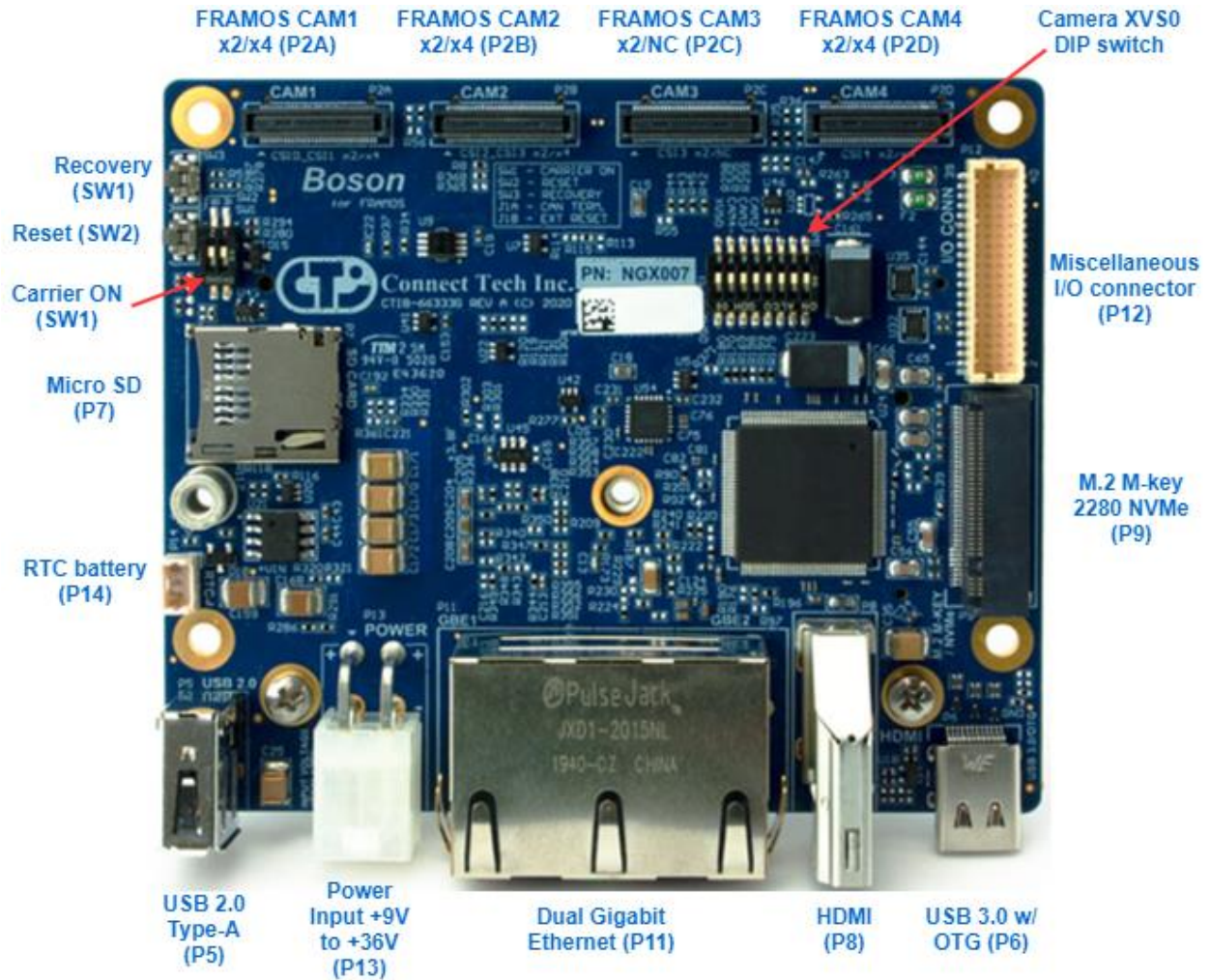

Bottom side

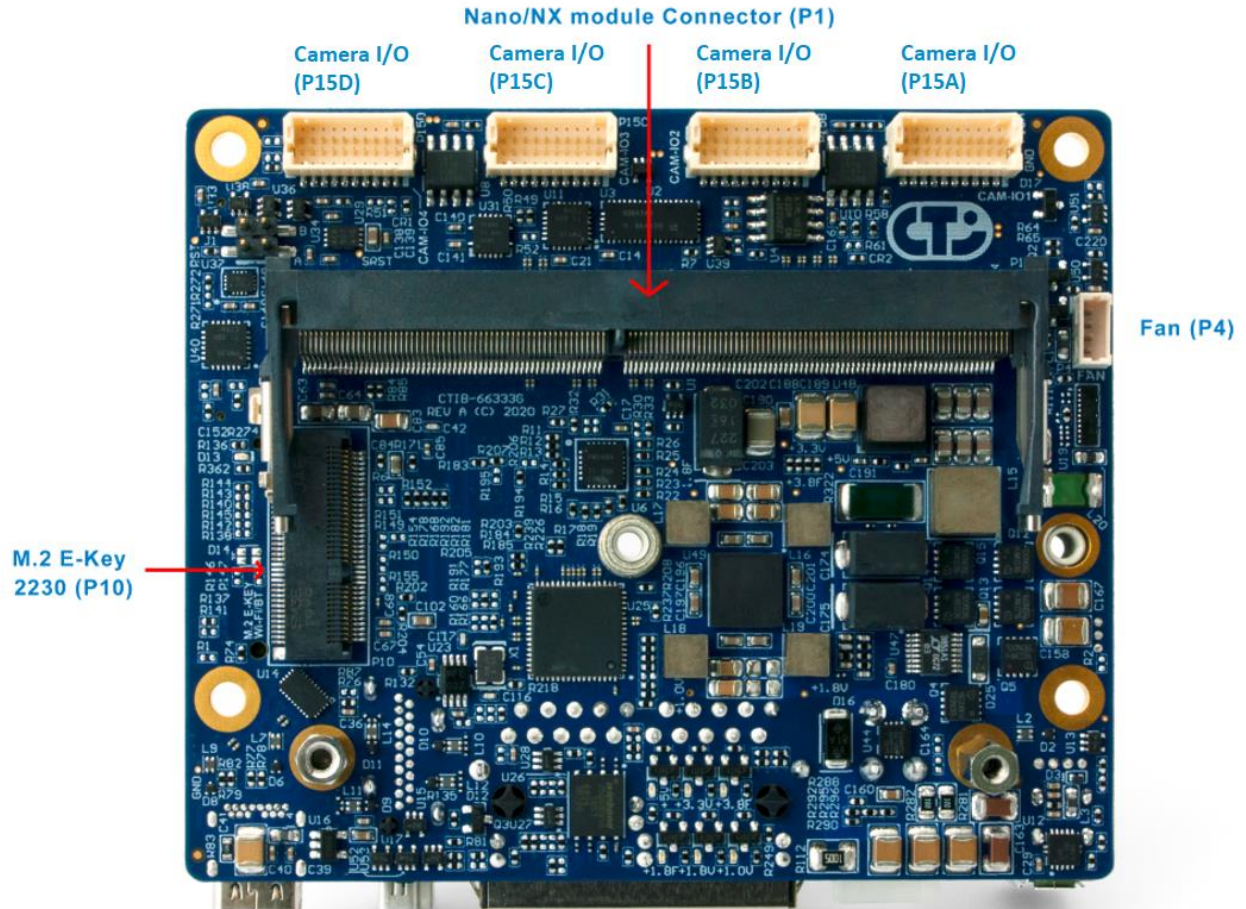

Connector Summary

Designator	Connector	Description
P1	Jetson Xavier™ NX / Jetson TX2™ NX / Jetson Nano™ / module connector	NVIDIA® Jetson Xavier™ NX / Jetson TX2™ NX / Jetson Nano™ Module Board-To-Board Connector
P2A, P2B, P2C, P3	MIPI CSI x4 connectors by FRAMOS	FRAMOS MIPI CSI x4/x2 Connector
P4	Fan connector	Active heatsink fan Connector for Jetson Xavier™ NX / Nano™
P5	USB 2.0	USB2.0 Type-A Connector
P6	USB 3.1 OTG	USB 3.1 Type-C Connector with OTG Gen 2 with Jetson Xavier™ NX. Gen 1 with Jetson Nano™/TX2™ NX
P7	MicroSD card	microSD Card Connector
P8	HDMI	HDMI Video Connector
P9	M.2 M-key slot	M.2 2280 M-Key NVMe SSD Connector
P10	M.2 E-key slot	M.2 2230 E-Key Wi-Fi/Bluetooth Module Connector Not supported with Jetson Nano™
P11	Dual Gigabit ethernet	Dual RJ-45 Gigabit Ethernet Connector 10/100/1000 Base-T connection Jetson Nano™ only supports one of the two GbE ports
P12	Misc. I/O Connector DF20G-40DP-1V(56)	Miscellaneous I/O connector. UART, SPI, I2C, GPIOs (w/ 2x PWM), CAN CAN not available with Jetson Nano™
P13	Power input connector 0353180420	+9V to +36V Mini-Fit Jr. 4-Pin DC Power Input Connector
P14	RTC battery 53047-0310	RTC Battery Connector
P15A, P15B, P15C, P15D	Camera I/O connectors DF20EG-20DP-1V(52)	I/O Connectors for FRAMOS camera signals

Switch and Jumper Summary

Designator	Function	Description
S1	FRAMOS Camera XVS0 Selection	FRAMOS Camera XVS0 and XHS0 Selection 8 Position SPST DIP switch
SW1	Carrier Power ON with no module	Do not use, test use only (DIP switch for Carrier Power ON with no module)
SW2	Reset pushbutton	Reset Pushbutton, press to initiate reset
SW3	Force Recovery pushbutton	Force Recovery Pushbutton, press to initiate recovery mode and flash new image via USB OTG
J1-A J1-B	CAN termination jumper External Reset TMM-102-01-L-D-SM	J1-A: CAN Termination. Populate jumper to add termination J1-B: External reset

DETAILED FEATURE DESCRIPTION

NVIDIA® Jetson Xavier™ NX / Jetson TX2™ NX/ Jetson Nano™ and Module Connector

The NVIDIA® Jetson Xavier™ NX, Jetson TX2™ NX, Jetson Nano™ and processor and chipset are implemented on the Jetson Modules. This connects to the NVIDIA® Jetson SoM to the Boson for FRAMOS carrier board via a TE Connectivity DDR4 SODIMM 260 Pin connector.

Function	Description
Location	P1
Type	Module Connector
Pinout	Refer to NVIDIA® Module Datasheets.
Features	Refer to NVIDIA® Module Datasheets.

NVIDIA® Jetson Xavier™ NX

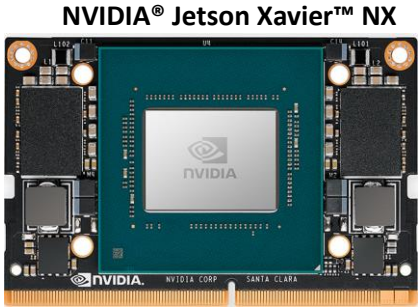

NVIDIA® Jetson TX2™ NX

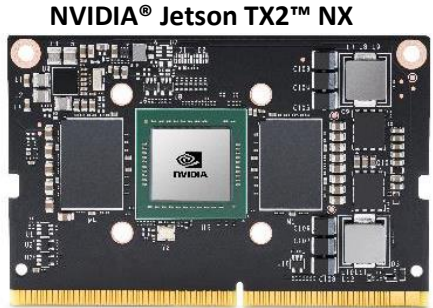

NVIDIA® Jetson Nano™



SO DIMM connector for module



FAN Connector

Boson for FRAMOS implements a 4 Position Molex PicoBlade connector for active cooling capability.

Function	Description	
Location	P4	
Type	Fan Connector Molex 4 Position 1.25mm PicoBlade Connector	
Carrier Connector	Part Number: 53047-0410 Manufacturer: Molex	
Mating Connector	Molex 0510210400 PicoBlade Connector	
Pinout	Pin	Description
	1	GND
	2	+5V_FAN
	3	FAN_TACH
	4	FAN_PWM



HDMI Connector

The NVIDIA® Jetson Nano™ and Xavier™ NX modules will output video via the Boson for FRAMOS Right Angle HDMI connector that is HDMI 2.0 capable.

Function	Description
Location	P8
Type	HDMI Right Angle Connector
Mating Connector	HDMI Type-A Cable
Pinout	Refer to HDMI Standard



FRAMOS MIPI CSIx4 Connectors

The Boson for FRAMOS carrier board allows FRAMOS MIPI CSIx4/CSIx2 video through the DF40HC(4.0)-60DS-0.4V(51) connectors.

Function	Description			
Location	P2A, B, D			
Type	FRAMOS MIPI CSIx4/x2 Connector (60-pin)			
Mating Connector	Mating connector: DF40C-60DP-0.4V(51) Flex cable: FMAFC-150/60			
Pinout	Pin	Description	Pin	Description
	1	+3.8V	2	+1.8V
	3	+3.8V	4	+1.8V
	5	NC	6	NC
	7	NC	8	NC
	9	NC	10	NC
	11	GND	12	GND
	13	GND	14	GND
	15	CAM_RST_0	16	NC
	17	NC	18	NC
	19	NC	20	NC
	21	SCL_A (I2C_0_SCL)	22	SCL_B (I2C_1_SCL)
	23	NC	24	NC
	25	XVSO	26	NC
	27	SDA_A (I2C_0_SDA)	28	SDA_B (I2C_1_SDA)
	29	XHS0 (CAM_GPIO2)	30	NC
	31	NC	32	NC
	33	CAM_PW_EN_0	34	CAM_PW_EN_1
	35	NC	36	NC
	37	GND	38	GND
	39	MCLK_0	40	NC
	41	MCLK_1	42	NC
	43	GND	44	GND
	45	ALTCLK_P	46	DATA3_P
	47	ALTCLK_N	48	DATA3_N
	49	GND	50	GND
	51	DATA0_N	52	DATA1_N
	53	DATA0_P	54	DATA1_P
	55	GND	56	GND
	57	DATA2_P	58	CLK_P
	59	DATA2_N	60	CLK_N



FRAMOS MIPI CSIx2 Connector

Boson for FRAMOS carrier board allows FRAMOS MIPI CSIx2 video through the DF40HC(4.0)-60DS-0.4V(51) connectors.

Function	Description			
Location	P2C			
Type	FRAMOS MIPI CSIx2/NC Connector (60-pin)			
Mating Connector	Mating connector: DF40C-60DP-0.4V(51) Flex cable: FMAFC-150/60			
Pinout	Pin	Description	Pin	Description
	1	+3.8V	2	+1.8V
	3	+3.8V	4	+1.8V
	5	NC	6	NC
	7	NC	8	NC
	9	NC	10	NC
	11	GND	12	GND
	13	GND	14	GND
	15	CAM_RST_0	16	NC
	17	NC	18	NC
	19	NC	20	NC
	21	SCL_A (I2C_0_SCL)	22	SCL_B (I2C_1_SCL)
	23	NC	24	NC
	25	XVSO	26	NC
	27	SDA_A (I2C_0_SDA)	28	SDA_B (I2C_1_SDA)
	29	XHS0 (CAM_GPIO2)	30	NC
	31	NC	32	NC
	33	CAM_PW_EN_0	34	CAM_PW_EN_1
	35	NC	36	NC
	37	GND	38	GND
	39	MCLK_0	40	NC
	41	MCLK_1	42	NC
	43	GND	44	GND
	45	NC	46	NC
	47	NC	48	NC
	49	GND	50	GND
	51	DATA0_N	52	DATA1_N
	53	DATA0_P	54	DATA1_P
	55	GND	56	GND
	57	NC	58	CLK_P
	59	NC	60	CLK_N



Camera I/O Connectors

The Boson for FRAMOS carrier board allows for access to FRAMOS camera I/O signals and power rails through DF20EG-20DP-1V(52) connectors.

Function	Description			
Location	P15A, P15B, P15C, P15D			
Type	I/O Connector for FRAMOS camera signals Hirose 20 Position 1 mm Connector			
Carrier Connector	Part Number: DF20EG-20DP-1V(52) Manufacturer: Hirose Electric Co Ltd			
Mating Connector	Mating connector: DF20A-20DS-1C			
Pinout	Pi	Description	Pi	Description
	n		n	
	1	+3.8V	2	+1.8V
	3	GPIO14	4	RST_1
	5	GPIO0 (XMASTER0)	6	GPIO15 (SPI_MISO)
	7	GPIO17 (SPI_CS)	8	GPIO8
	9	GPIO9	10	GPIO16 (SYS_PW_EN)
	11	GPIO2 (XHS0)	12	GPIO10
	13	GPIO3 (XTRIG0)	14	GPIO11 (FSTROBE)
	15	GPIO6	16	GPIO7
	17	GPIO1 (XVS0)	18	GPIO4 (MCLK2)
	19	GND	20	GND

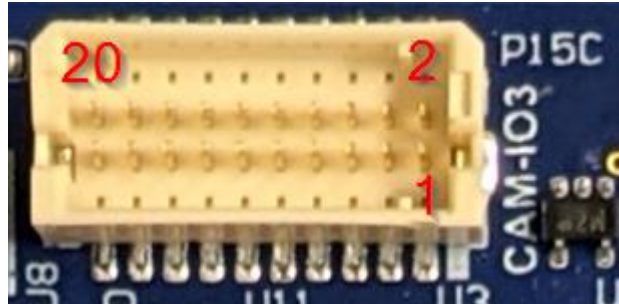

USB 3.1 w/OTG Gen 1 / 2 Type-C Connector

Boson for FRAMOS incorporates a USB3.1 Gen 1 / 2 Type-C Connector with a 2A current limit. Allows host mode access to the module or OTG flashing of the module.

Function	Description	
Location	P6	
Type	USB Type-C Connector w/ OTG	
Mating Connector	USB Type-C Cable	
Pinout	Refer to USB Standard	

Note 1: If using the Jetson TX2™ NX or Jetson Nano™ Module, USB 3.1 Gen 1 is the fastest speed available to the connector.

Note 2: If using the Jetson Xavier™ NX Module, USB 3.1 Gen 2 is the fastest speed available to this connector.

10/100/1000 Dual Ethernet Connector

Boson for FRAMOS includes a Dual RJ-45 ethernet connector for internet communication. One RJ45 Ethernet port is directly connected to the module while the other is through a PCIe Gigabit Ethernet PHY.

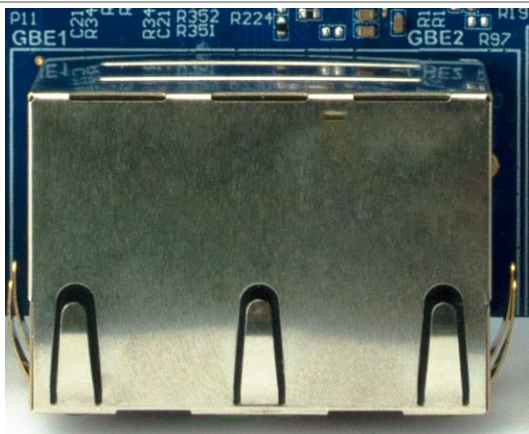
Function	Description	
Location	P11	
Type	2x RJ-45 Connector	
Mating Connector	RJ-45 Ethernet Cable	
Pinout	Refer to Ethernet Standard	

Note: If using Jetson Nano™ module, only one GBE port (labeled GBE1) is functional.

M.2 M-key 2280 NVMe Connector

Boson for FRAMOS implements an M.2 2280 M-Key for a PCIe x4 Gen 2 NVMe.

Function	Description	
Location	P9	
Type	M.2 M-key 2280	
Mating Connector	M-key NVMe	
Pinout	Refer to M.2 standard NGFF	

M.2 E-key 2230 Wi-Fi/BT Connector

Boson for FRAMOS implements an M.2 2230 E-Key for a PCIe x1, USB 2.0 Wi-Fi/Bluetooth Module.

Function	Description	
Location	P10	
Type	M.2 E-key 2230	
Mating Connector	E-key Wifi/BT module	
Pinout	Refer to M.2 standard	

Note: Not supported with Jetson Nano™ module

USB 2.0 Type-A Connector

Boson for FRAMOS incorporates a USB2.0 Type-A Connector with a 1A current limit.

Function	Description	
Location	P5	
Type	Type-A USB Connector	
Mating Connector	Type-A USB Connector	

microSD Card Connector

Boson for FRAMOS implements a micro-SD card connector.

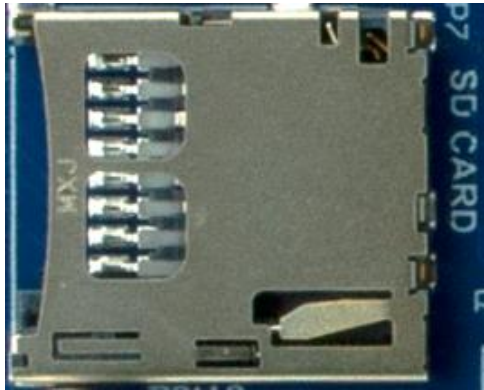
Function	Description	
Location	P7	
Type	microSD Card Connector	
Pinout	Refer to SD Card Standard	

Misc. I/O Connector

Boson for FRAMOS implements a Hirose DF20G-40DP-1V(56) Connector to allow for additional user control. 2x SPI (SPI0, SPI1), 3x UART (UART0, UART1, UART2 – DEBUG), 2x I2C (I2C0, I2C1), 1x CAN, 6x GPIO (From I2C Expander), and 2x PWM (GPIO07 From Module, GPIO13 From Module).

Note: CAN not supported with Jetson Nano™ module

Function	Description		
Location	P12		
Type	Misc. I/O Expansion Connector		
Carrier Connector	DF20G-40DP-1V(56)		
Mating Connector	DF20A-40DS-1C		
Pinout	Pin	Description	I/O Type
	1	+5V	Power
	2	SPI0_MOSI (3.3V Max.)	O
	3	SPI0_MISO (3.3V Max.)	I
	4	SPI0_SCK (3.3V Max.)	O
	5	SPI0_CS0# (3.3V Max.)	O
	6	+3.3V	Power
	7	GND	Power
	8	SPI1_MOSI (3.3V Max.)	O
9	SPI1_MISO (3.3V Max.)	I	

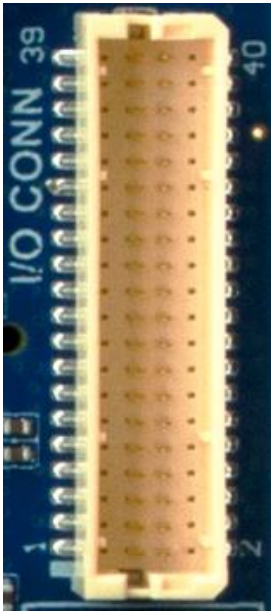

10	SPI1_SCK (3.3V Max.)	O
11	SPI1_CS0# (3.3V Max.)	O
12	GND	Power
13	UART2_TX (3.3V Max., Console debug)	O
14	UART2_RX (3.3V Max., Console debug)	I
15	GND	Power
16	I2C0_SCL (3.3V Max.)	I/O
17	I2C0_SDA (3.3V Max.)	I/O
18	GND	Power
19	GPIO0 (3.3V Max.)	I/O
20	GPIO1 (3.3V Max.)	I/O
21	GND	Power
22	GPIO2 (3.3V Max.)	I/O
23	GPIO3 (3.3V Max.)	I/O
24	GPIO4 (3.3V Max.)	I/O
25	GPIO5 (3.3V Max.)	I/O
26	GND	Power
27	UART0_RX (3.3V Max.)	I
28	I2C1_SCL (3.3V Max.)	I/O
29	GND	Power
30	UART0_TX (3.3V Max.)	O
31	CANH	I/O
32	CANL	I/O
33	GPIO07 (PWM1, 3.3V Max.)	O
34	GPIO13 (PWM2, 3.3V Max.)	O
35	+5V	Power
36	UART1_TX (3.3V Max.)	O
37	UART1_RX (3.3V Max.)	I
38	+3.3V	Power
39	I2C1_SDA (3.3V Max.)	I/O
40	GND	Power

Power Connector

Boson for FRAMOS implements a Mini-Fit Jr. 4-Pin Power Connector that accepts +9V to +36V DC power.

Function	Description
Location	P13
Type	Mini-Fit Jr. 4-Pin Connector
Minimum Input Voltage	+9V DC
Maximum Input Voltage	+36V DC

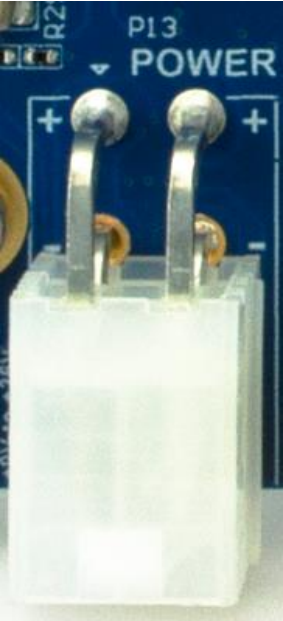

RTC Battery Connector

Function	Description
Location	P14
Type	Molex 3 Position 1.25mm PicoBlade Connector
Carrier Connector	Part Number: 53047-0310 Manufacturer: Molex
Mating Connector	Molex 51021-0300 PicoBlade Connector
Mating CTI Cable	CBG136
Pinout	
Pin 1	RTC Battery Positive (+ve)
Pin 2	Not Connected
Pin 3	RTC Battery Negative (-ve)



Reset Pushbutton

Boson for FRAMOS implements a RESET pushbutton. Push this button to initiate reset sequence.

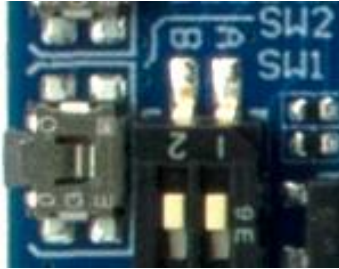
Function	Description	
Location	SW2	
Type	Pushbutton	

Force Recovery Pushbutton

Boson for FRAMOS implements a FORCE RECOVERY pushbutton. This is required for flashing a new image on to the SoM.

To put into Force Recovery mode, hold down the Force Recovery button and push-release the RESET button while still holding down the Force Recovery. Now release Force Recovery button.

Function	Description	
Location	SW3	
Type	Pushbutton	

Carrier Power ON – no module

Boson for FRAMOS allows for the platform to have the carrier's power rails turned ON when no Jetson NVIDIA® module is connected. To enable this, move the DIP switches to the ON position.

Function	Description	
Location	SW1	
Type	2 position DIP switch	

Camera XVS0 and XHS0 DIP switch

Boson for FRAMOS implements an 8 position DIP Switch for the selection of different FRAMOS Camera XVS0 and XHS0 signals for camera synchronization.

Default setting: All switches are in OFF position. XVS0 and XHS0 signals from all cameras are unconnected.

For **external sync or slave mode sync** for the cameras, DIP switches for the XVS0 and XHS0 of the cameras of interest can be put in the ON position.

When in the XVS0 DIP switches are in the ON position, the XVS0 signals of the cameras of interest get connected to each other and to GPIO01 of the Jetson Xavier™ NX/Nano™/TX2™ NX module.

Similarly, in the ON position of the XHS0 DIP switches, the XHS0 signals of the cameras of interest get connected to each other.

Function	Description			
Location	S1			
Type	8 position DIP switch			
Pinout	Pin	Description	Pin	Description
	1	CAM0_XVS0	2	XVS0
	3	CAM0_XHS0	4	XHS0
	5	CAM1_XVS0	6	XVS0
	7	CAM1_XHS0	8	XHS0
	9	CAM2_XVS0	10	XVS0
	11	CAM2_XHS0	12	XHS0
	13	CAM3_XVS0	14	XVS0
	15	CAM3_XHS0	16	XHS0



Jumper for CAN termination and External Reset

Boson for FRAMOS implements a 2 position Jumper for Enabling or Disabling the CAN Termination Resistor of 120Ω and a location for external RESET.

Function	Description
Location	J1
Type	Jumper
J1A	CAN Termination Enable/Disable Populate jumper to enable 120Ω termination
J1B	External RESET. Place jumper to put carrier in permanent RESET. Or use as a location to connect an external push button.



TYPICAL INSTALLATION

1. Ensure all external system power supplies are off and disconnected.
2. Install the necessary cables for your application. At a minimum these would include:
 - a. Power cable to the input power connector.
 - b. Ethernet cable into its port (if applicable).
 - c. HDMI video display cable (if applicable).
 - d. Keyboard, Mouse, etc. via USB (if applicable).
 - e. microSD Card (if applicable).
 - f. FRAMOS Camera(s) (if applicable).
 - g. Misc. GPIO 40-Pin Connector (if applicable).
 - h. M.2 2230 WiFi/BT Module and Antennas for WiFi/Bluetooth (if applicable).
 - i. M.2 2280 NVMe (if applicable).
 - j. Connect the Power Cable of the +9V to +36V Power Supply into the Mini-Fit Jr. 4-Pin power connector.
3. Plug the AC cable into the Power Supply and into the wall socket.
DO NOT power up your system by plugging in live power.
4. To flash a module with the Boson, put the carrier in Force Recovery mode. Follow these steps:
 - a. Install the Xavier™ NX or Nano™ module at P1
 - b. Connect Power at P13
 - c. Connect BOSON to a PC with a USB type-C cable at P6
 - d. Press SW2 (RESET) and SW3 (RECOVERY) at the same time
 - e. Release SW2 (RESET) first while continuing to hold down SW3 (RECOVERY)
 - f. Release SW3 (RECOVERY) after 1 to 2 seconds.
 - g. The board should now be in Force Recovery mode and should appear as NVIDIA® Corp. in the terminal of the PC and can now be flashed

POWER CONSUMPTION & THERMALS

Boson for FRAMOS has an Operating Temperature Range of -25°C to +85°C. However, it is important to note that the NVIDIA® Jetson™ module has its own properties separate to that of the Boson for FRAMOS Carrier Board, and care should be taken to not exceed module maximum component temperatures.

Customer responsibility requires proper implementation of a thermal solution that maintains the Boson for FRAMOS carrier board and module temperatures below the specified temperatures (shown in the tables below) under the maximum thermal load and system conditions for their use case.

NVIDIA® Jetson Nano™

Parameter	Value	Units
Maximum Nano™ SoC Operating Temperature	T.cpu = 90.5	°C
	T.gpu = 91.5	°C
	T.aux = 90.0	°C
Nano™ SoC Shutdown Temperature	T.cpu = 96.0	°C
	T.gpu = 97.0	°C
	T.aux = 95.5	°C

NVIDIA® Jetson Xavier™ NX

Parameter	Value	Units
Maximum Xavier™ NX SoC Operating Temperature	T.cpu = 90.5	°C
	T.gpu = 91.5	°C
	T.aux = 90.0	°C
Xavier™ NX SoC Shutdown Temperature	T.cpu = 96.0	°C
	T.gpu = 97.0	°C
	T.aux = 95.5	°C

CURRENT CONSUMPTION DETAILS

Parameter	Value	Units	Value	Units	Temperature
Boson for FRAMOS with NVIDIA® Jetson Xavier™ NX module Installed, Fully-Booted, Idle, Passive Cooling	12	V	6.1	W	25°C (typ.)
Boson for FRAMOS with NVIDIA® Jetson Xavier™ NX module Installed, Fully-Booted, Idle, Passive Cooling and external cooling fan, 4 Cameras streaming and displaying	12	V	13.8	W	25°C (typ.)

SOFTWARE / BSP DETAILS

All of Connect Tech's NVIDIA® Jetson based products are built upon a modified Linux for Tegra (L4T) Device Tree that is specific to each unique product.

WARNING: The hardware configurations of Connect Tech's products differ from that of the NVIDIA® supplied evaluation kit. Please review the product documentation and install **ONLY** the appropriate Connect Tech L4T BSPs. Failure to follow this process could result in non-functional hardware.

CABLES (NOT INCLUDED)

Description	Part Number	Qty
Power Input Cable	CBG408	1
Misc. I/O Cable	CBG125	1
Camera I/O Cable	CBG509	4
RTC Battery Cable	CBG136	1

ACCESSORIES

Description	Part Number
AC/DC Power Supply	MSG085

RECOMMENDED CAMERAS

Recommended Cameras				
Vendor	Product Name	Image Sensor	Sensor Type	Max Resolution
FRAMOS	FSM-AR0144	AR0144	Global Shutter	1M (1280×800)
FRAMOS	FSM-AR0521	AR0521	Rolling Shutter	5M (2592×1944)
FRAMOS	FSM-AR1335 Color	AR1335	Rolling Shutter	4K (4208×3120)
FRAMOS	FSM-HDP230	HDPYX 230-G	Global Shutter	HD (1944×1204)
FRAMOS	FSM-IMX264	IMX264	Global Shutter	5.1M (2464×2056)
FRAMOS	FSM-IMX283 Color	IMX283	Rolling Shutter	4K (5496×3694)
FRAMOS	FSM-IMX290 Mono	IMX290	Rolling Shutter	HD (1920×1080)
FRAMOS	FSM-IMX296	IMX296	Global Shutter	1.6M (1456×1088)
FRAMOS	FSM-IMX297	IMX297	Global Shutter	0.4M (728×544)
FRAMOS	FSM-IMX304	IMX304	Global Shutter	4K (4112×3008)
FRAMOS	FSM-IMX327 Color	IMX327	Rolling Shutter	HD (1920×1080)
FRAMOS	FSM-IMX334	IMX334	Rolling Shutter	4K (3864×2180)
FRAMOS	FSM-IMX335	IMX335	Rolling Shutter	5M (2616×1964)
FRAMOS	FSM-IMX412 Color	IMX412	Rolling Shutter	4K (4056×3040)
FRAMOS	FSM-IMX415 Color	IMX415	Rolling Shutter	4K (3864×2192)
FRAMOS	FSM-IMX462 Color	IMX462	Rolling Shutter	HD (1920×1080)
FRAMOS	FSM-IMX464 Color	IMX464	Rolling Shutter	4.2M (2712×1538)
FRAMOS	FSM-IMX477 Color	IMX477	Rolling Shutter	4K (4056×3040)
FRAMOS	FSM-IMX485 Color	IMX485	Rolling Shutter	4K (3864×2180)
FRAMOS	FSM-IMX530	IMX530	Global Shutter	4K (5328×4608)
FRAMOS	FSM-IMX577 Color	IMX577	Rolling Shutter	4K (4056×3040)