

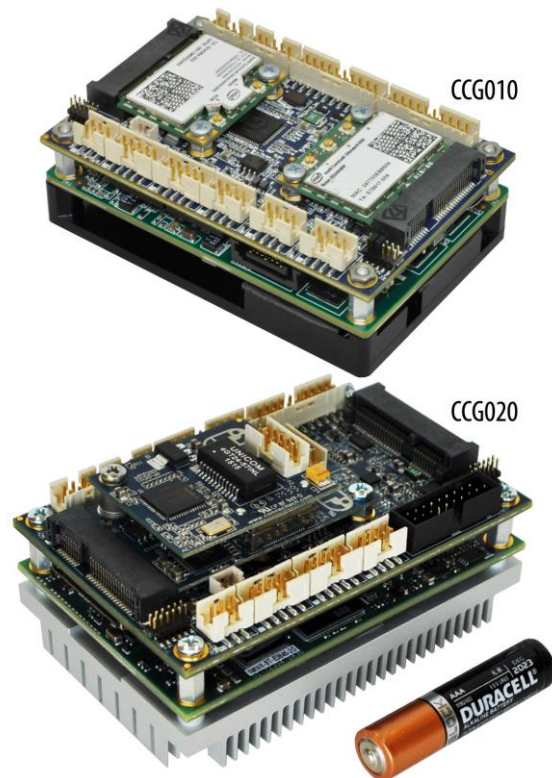

Connect Tech Inc.
Embedded Computing Experts

COM Express[®] Type 10 Mini Carrier CCG010 / CCG020 Users Guide



Connect Tech Inc.
42 Arrow Road
Guelph, Ontario
N1K 1S6

Tel: 519-836-1291
Toll: 800-426-8979 (North America only)
Fax: 519-836-4878
Email: sales@connecttech.com
support@connecttech.com
Web: www.connecttech.com

CTIM-00120 Revision: 0.04 October 7, 2015

Table of Contents

Customer Support Overview	4
Contact Information.....	4
Limited Lifetime Warranty.....	5
Copyright Notice	5
Trademark Acknowledgment	5
Revision History	5
Introduction	6
ESD Warning.....	6
Product Features and Specifications	7
Block Diagram	8
Connector Locations.....	9
Connector Summary	11
Jumper Summary.....	11
Detailed Feature Pinouts and Functional Descriptions	12
COM Express Module Connector	12
Input Power Connector	12
DisplayPort ++ (DDI) Video Connector	13
HDMI / DVI / VGA	13
LVDS Video Connector.....	14
LVDS Backlight Power Connector	15
USB 2.0 Port Connectors	15
USB 3.0/2.0 Port Connectors.....	16
10/100/1000 Ethernet (GBE) Connector.....	17
Software Support for the Intel 82574	17
Audio Interface Connector.....	18
Software Support for the CS4207	18
External SATA (CCG010 Only).....	19
mini PCIe & mSATA Slots.....	20
Dual Function mini PCIe mSATA Slots	20
Half and Full Length mini PCIe / mSATA module Installation	21
Standoff and Screw Assembly Details	21
CCG020 – External Hard Drive Installation	21
mini pcie / mSATA Connector Pinout	22
Asynchronous Serial RS-232/485 Connector.....	23
RS-232/485 Connector.....	23
RS-232/485 Jumper Configuration	23
microSD Card Connector.....	24
Misc/System Connector	25
RTC Battery Connector	26
Typical Hardware Installation Procedure	27
On-board Indicator LEDs (CCG010 Only).....	27

Jumper Settings	28
Current Consumption Details	29
Thermal Details	29
Mechanical Details	30
Cables and Cable Kit Information	31
Cable Kits	31
Detailed Cable Information.....	33
RJ-45 panel mount to 10-pin MiniTek w/Latch - CBG117.....	33
Dual 3.5mm Stereo Audio panel mount to 8-pin MiniTek w/Latch - CBG118.....	34
Dual USB 2.0 panel mount to 8-pin MiniTek w/Latch - CBG104.....	35
DisplayPort++ panel mount to 20-pin MiniTek w/Latch - CBG113	36
Dual DB-9 panel mount to 10-pin MiniTek w/Latch - CBG111	37
3V CR2032 RTC Battery with 3-pin Connector and Cable Assembly - 6032101013.....	38
System Cable - Unterminated wires to 20-pin MiniTek w/Latch - CBG116.....	39
Power Cable - Unterminated wires to 6-pin MiniTek w/Latch - CBG112	40
CBG131 - Dual USB 3.0 to 20-Pin Cable.....	41

Customer Support Overview

If you experience difficulties after reading the manual and/or using the product, contact the Connect Tech reseller from which you purchased the product. In most cases the reseller can help you with product installation and difficulties. In the event that the reseller is unable to resolve your problem, our highly qualified support staff can assist you. Our support section is available 24 hours a day, 7 days a week on our website at: www.connecttech.com/sub/support/support.asp. See the contact information section below for more information on how to contact us directly. Our technical support is always free.

Contact Information

Mail/Courier

Connect Tech Inc.
Technical Support
42 Arrow Road
Guelph, Ontario
Canada N1K 1S6

Email/Internet

sales@connecttech.com
support@connecttech.com
www.connecttech.com

Note:

Please go to the [Download Zone](#) or the [Knowledge Database](#) in the [Support Center](#) on the Connect Tech website for product manuals, installation guides, device driver software and technical tips. Submit your technical support questions to our customer support engineers via the [Support Center](#) on the Connect Tech website.

Telephone/Facsimile

Technical Support representatives are ready to answer your call Monday through Friday, from 8:30 a.m. to 5:00 p.m. Eastern Standard Time. Our numbers for calls are:

Toll Free: 800-426-8979 (North America only)

Telephone: 519-836-1291 (Live assistance available 8:30 a.m. to 5:00 p.m. EST, Monday to Friday)

Facsimile: 519-836-4878 (on-line 24 hours)

Limited Lifetime Warranty

Connect Tech Inc. provides a Lifetime Warranty for all Connect Tech Inc. products. Should this product, in Connect Tech Inc.'s opinion, fail to be in good working order during the warranty period, Connect Tech Inc. will, at its option, repair or replace this product at no charge, provided that the product has not been subjected to abuse, misuse, accident, disaster or non-Connect Tech Inc. authorized modification or repair.

You may obtain warranty service by delivering this product to an authorized Connect Tech Inc. business partner or to Connect Tech Inc. along with proof of purchase. Product returned to Connect Tech Inc. must be pre-authorized by Connect Tech Inc. with an RMA (Return Material Authorization) number marked on the outside of the package and sent prepaid, insured and packaged for safe shipment. Connect Tech Inc. will return this product by prepaid ground shipment service.

The Connect Tech Inc. Lifetime Warranty is defined as the serviceable life of the product. This is defined as the period during which all components are available. Should the product prove to be irreparable, Connect Tech Inc. reserves the right to substitute an equivalent product if available or to retract Lifetime Warranty if no replacement is available.

The above warranty is the only warranty authorized by Connect Tech Inc. Under no circumstances will Connect Tech Inc. be liable in any way for any damages, including any lost profits, lost savings or other incidental or consequential damages arising out of the use of, or inability to use, such product.

Copyright Notice

The information contained in this document is subject to change without notice. Connect Tech Inc. shall not be liable for errors contained herein or for incidental consequential damages in connection with the furnishing, performance, or use of this material. This document contains proprietary information that is protected by copyright. All rights are reserved. No part of this document may be photocopied, reproduced, or translated to another language without the prior written consent of Connect Tech, Inc.

Copyright © 2015 by Connect Tech, Inc.

Trademark Acknowledgment

Connect Tech, Inc. acknowledges all trademarks, registered trademarks and/or copyrights referred to in this document as the property of their respective owners.

Not listing all possible trademarks or copyright acknowledgments does not constitute a lack of acknowledgment to the rightful owners of the trademarks and copyrights mentioned in this document.

Revision History

Revision	Date	Changes
0.00	08/06/2013	Original
0.01	02/25/2015	Pinout Updates
0.02	09/09/2015	Added CCG020 Information
0.03	09/21/2015	Corrected RS-232/RS-485 Pinout/Jumper Info
0.04	06/10/2015	Corrected Ethernet Naming Error and Fixed Naming Consistency

Introduction

Connect Tech's COM Express® Type 10 Mini Carrier Board is an extremely small carrier board featuring rugged, locking connectors and offers the ultimate durability.

COM Express® Type 10 Mini Carrier Board is ideal for space constrained applications, harsh environments, demanding conditions and supports extended temperature ranges of -40°C to +85°C.

ESD Warning



Electronic components and circuits are sensitive to ElectroStatic Discharge (ESD). When handling any circuit board assemblies including Connect Tech COM Express carrier assemblies, it is recommended that ESD safety precautions be observed. ESD safe best practices include, but are not limited to:

- Leaving circuit boards in their antistatic packaging until they are ready to be installed.
- Using a grounded wrist strap when handling circuit boards, at a minimum you should touch a grounded metal object to dissipate any static charge that may be present on you.
- Only handling circuit boards in ESD safe areas, which may include ESD floor and table mats, wrist strap stations and ESD safe lab coats.
- Avoiding handling circuit boards in carpeted areas.
- Try to handle the board by the edges, avoiding contact with components.

Product Features and Specifications

Specifications	
Compatibility	COM Express® Type 10 Mini Modules PICMG COM Express® COM.0 R2.1
Mini PCIe Expansion	2 x half size cards OR 1 x full length card Both sockets have PCIe and USB signaling, one socket also can be configured as mSATA.
Storage	CCG010: 1 x mSATA, 1 x 1 Ext RA 7-pin Connector CCG020: 1 x mSATA
USB	CCG010: 8 x USB 2.0 Ports (6 to connectors, 2 to miniPCIe) CCG020: 2 x USB 3.0 Ports (Only if supported by COM Express Module) 6 x USB 2.0 Ports (2 to USB 3.0 connector, 2 to USB 2.0 connector, 2 to miniPCIe)
Network	2 x Gigabit Ethernet (10/10/1000) Ports: 1 from COM Express 1 from on-board Intel 82574I PHY/Controller
GPIO	8-bit GPIO
Display	1 x DisplayPort++ (DDI) interface: Can be used for DisplayPort, HDMI, DVI or VGA 1 x LVDS interface (18-bit, 3 data pairs)
Audio	HD Audio (Cirrus Logic CS4207 codec) 1 x stereo input 1 x stereo output
Serial	2 x RS-232/422/485 hardware selectable ports
Misc External Interfaces	SMBus I2C Battery Low Indication System Status (S3 and Reset Outputs)
Power	Single wide input range +6V to +14V DC (may be module dependent)
Connectors	All shrouded locking ruggedized 2mm pitch headers. <ul style="list-style-type: none"> - Can be mated to CTI cable set which terminate to panel mountable PC type connectors. - As well can mated to customer cables sets to terminate to any customer or MIL type connectors
Mechanical Information	84mm x 55mm (Same as Type 10 mini Form Factor) CCG010/20: Download 3D model here
Weight	49g (carrier only, no module installed)
MTBF	1253592 hrs / 797.7073 FITs
Operating Temperature	-40°C to +85°C
Warranty and Support	Lifetime Warranty and Free Technical Support

Block Diagram

CCG010 Block Diagram

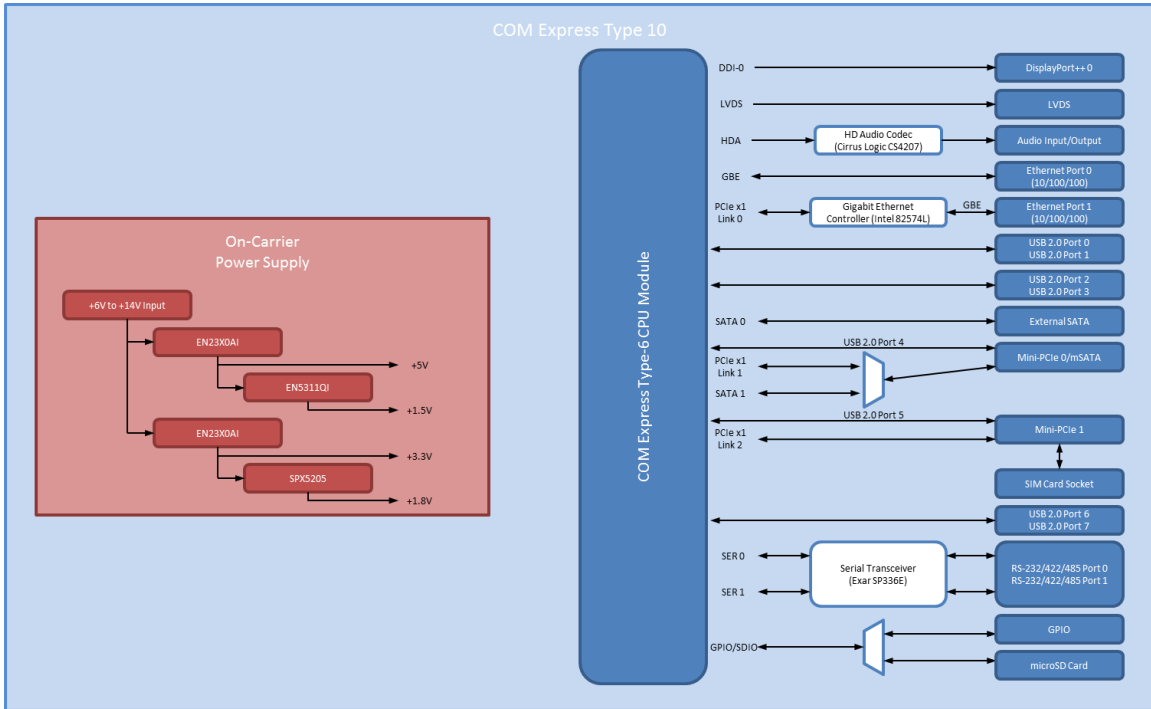

CCG020 Block Diagram

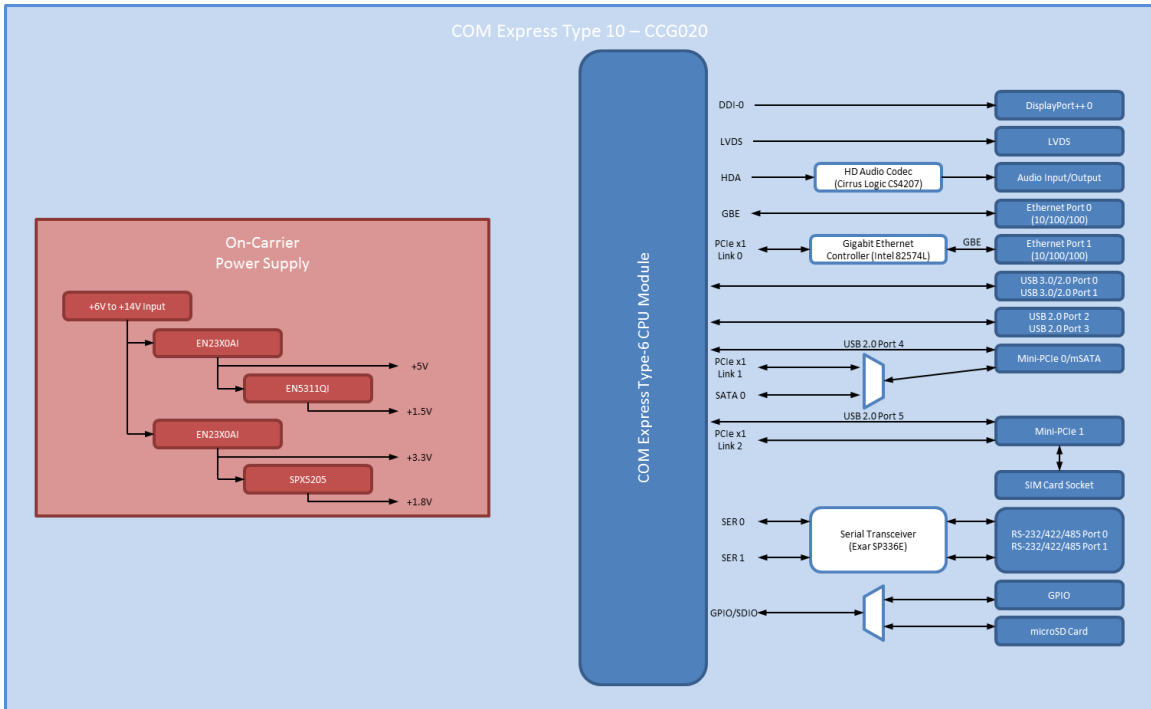

Connector Locations

CCG010 Top View

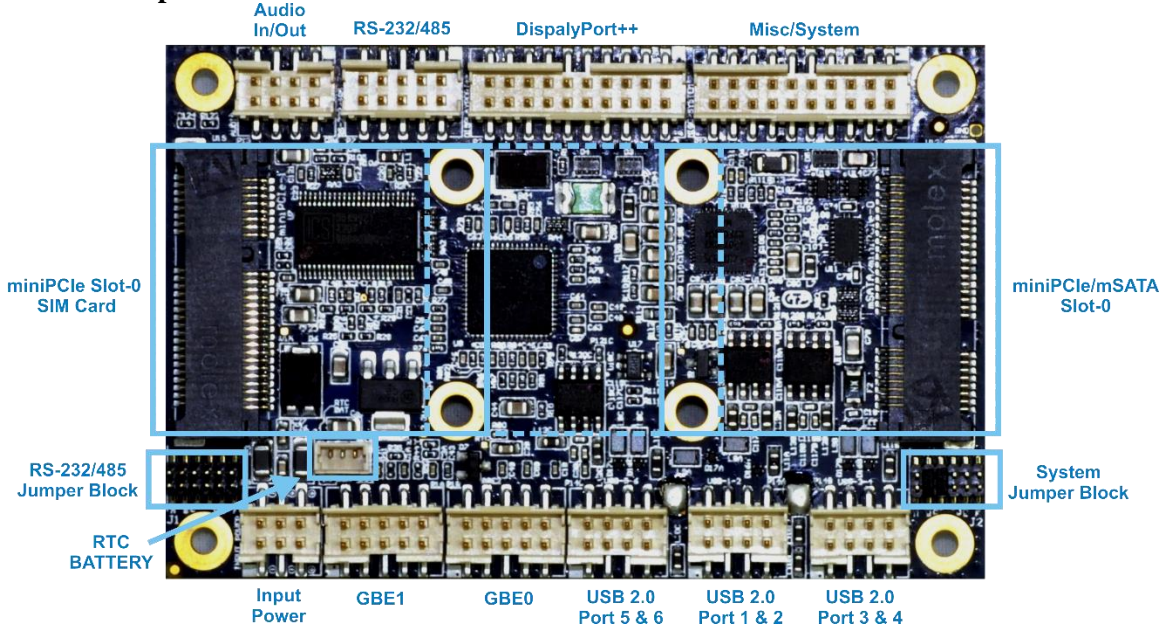

CCG010 Bottom View

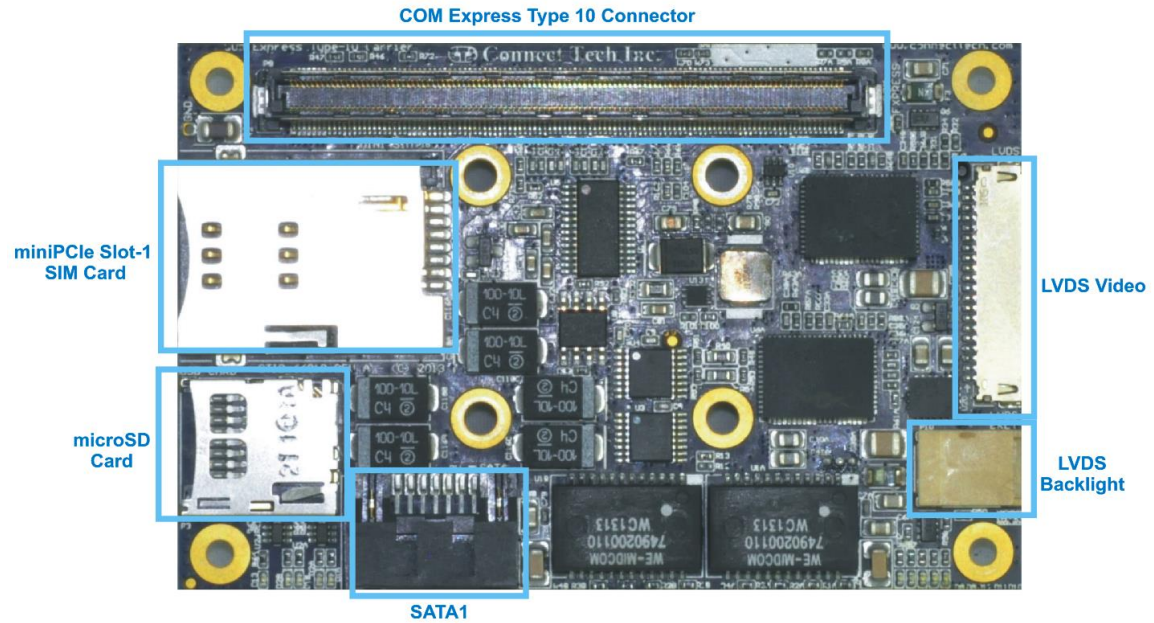

CCG020 Top View

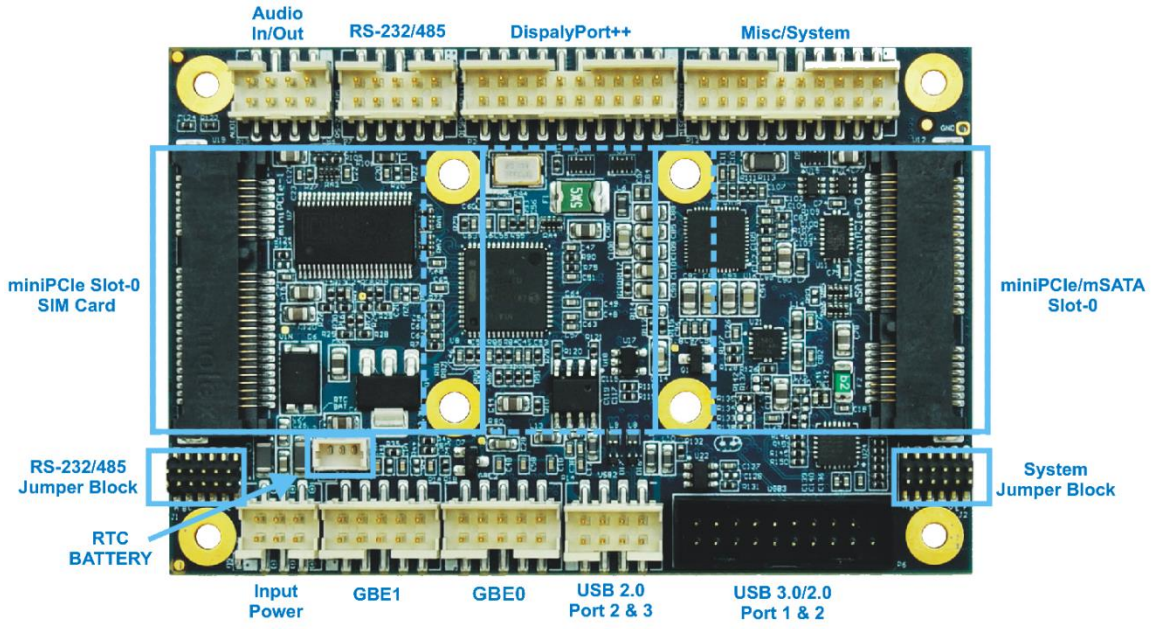

CCG020 Bottom View

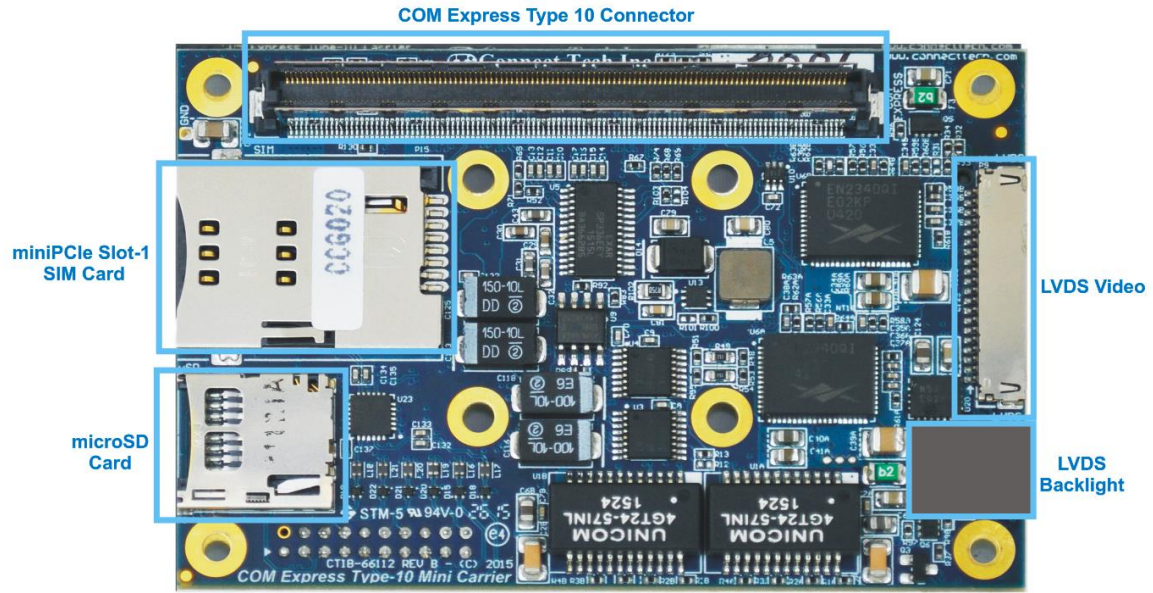

Connector Summary

Designator	Connector	Description
P1A	2x5 2mm Locking Pin-Header	GBE1 Connector
P1B	2x5 2mm Locking Pin-Header	GBE0 Connector
P2	2x10 2mm Locking Pin-Header	DisplayPort++ Connector
P3	microSD Card Socket	microSD Card Connector
P4	2x3 2mm Locking Pin-Header	Input Power Connector
P5	1x3 1.25mm Locking Header	RTC Battery Connector
P6	19-Pin 2mm Locking Header	USB 3.0 Connector (CCG020 only)
P7	2x5 2mm Locking Pin-Header	RS-232/485 Connector
P8	220-pin Board to Board Connector	COM Express Type 10 Connector
P9	20-pin Hirose Panel Connector	LVDS Video Connector
P10	2-pin Power Connector	LVDS Backlight Power Connector
P11	Right Angle SATA Connector	SATA 1 Connector
P12	2x10 2mm Locking Pin-Header	Misc/System Connector
P13	2x4 2mm Locking Pin-Header	Audio Input/Output Connector
P14A	2x4 2mm Locking Pin-Header	USB 2.0 Port 1 & 2 Connector
P14B	2x4 2mm Locking Pin-Header	USB 2.0 Port 3 & 4 Connector
P14C	2x4 2mm Locking Pin-Header	USB 2.0 Port 5 & 6 Connector

Jumper Summary

Designator	Jumper	Description
J1	6-position 1.27mm Jumper Block	RS-232/RS-485 Jumper Block
J2	6-position 1.27mm Jumper Block	Misc/System Jumper Block

Detailed Feature Pinouts and Functional Descriptions

COM Express Module Connector

The processor and chipset are implemented on the COM Express Type 10 CPU module, which connects to the COM Express carrier via a Tyco fine pitch stacking connector.

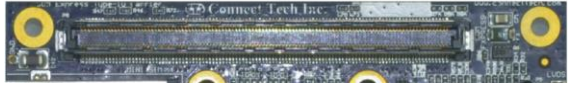
Function	COM Express interface	
Location	P1	
Carrier Connector PN	3-6318491-6 Manufacturer: TE Connectivity	
Mating Connector PN	3-1827231-6 Manufacturer: TE Connectivity	
Pinout	Refer to COM Express R2.0 specification, Type-10	

Input Power Connector

The COM Express Type 10 Mini Carrier accepts a single input to power all of the on board devices. All intermediate voltages are derived from this input. Most COM Express Type 10 module can accept a wide input voltage range, however the on-board power supplies on CTI's carrier can only accept up to a maximum of +14V.

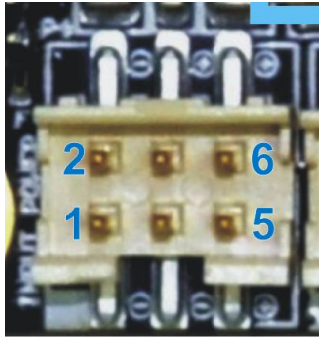
Function	Main Input Power																					
Location	P4																					
Input Range	+6 VDC to +14 VDC																					
Carrier Connector PN	98424-G52-06LF - Manufacturer: FCI																					
Mating Connector PN	10073599-006LF - Manufacturer: FCI																					
Pinout	<table border="1"> <thead> <tr> <th>Pin</th> <th>Signal</th> <th>Description</th> </tr> </thead> <tbody> <tr> <td>1</td> <td>GND</td> <td>Ground / Return</td> </tr> <tr> <td>2</td> <td>GND</td> <td>Ground / Return</td> </tr> <tr> <td>3</td> <td>GND</td> <td>Ground / Return</td> </tr> <tr> <td>4</td> <td>+VIN</td> <td>Power In</td> </tr> <tr> <td>5</td> <td>+VIN</td> <td>Power In</td> </tr> <tr> <td>6</td> <td>+VIN</td> <td>Power In</td> </tr> </tbody> </table>		Pin	Signal	Description	1	GND	Ground / Return	2	GND	Ground / Return	3	GND	Ground / Return	4	+VIN	Power In	5	+VIN	Power In	6	+VIN
Pin	Signal	Description																				
1	GND	Ground / Return																				
2	GND	Ground / Return																				
3	GND	Ground / Return																				
4	+VIN	Power In																				
5	+VIN	Power In																				
6	+VIN	Power In																				

DisplayPort ++ (DDI) Video Connector

The *COM Express Type 10 Mini Carrier* features a DisplayPort++ connector. This can be configured to output DisplayPort, HDMI/DVI or even VGA through the use of a dongle.

The configuration of each interface is setup via the COM Express module's BIOS settings. Refer to the COM Express module's documentation for more details.

Function	Main Input Power		
Location	P4		
Carrier Connector PN	98424-G52-20LF - Manufacturer: FCI		
Mating Connector PN	10073599-020LF - Manufacturer: FCI		
Pinout	Pin	Signal	Description
	1	DP0+	DisplayPort Pair 0
	2	DP3+	DisplayPort Pair 3
	3	DP0-	DisplayPort Pair 0
	4	DP3-	DisplayPort Pair 3
	5	GND	GND
	6	GND	GND
	7	DP1+	DisplayPort Pair 1
	8	DPAUX-	DisplayPort Auxiliary Pair
	9	DP1-	DisplayPort Pair 1
	10	DPAUX+	DisplayPort Auxiliary Pair
	11	GND	GND
	12	GND	GND
	13	DP2+	DisplayPort Pair 2
	14	DP.HPD	Hot Plug Detect
	15	DP2-	DisplayPort Pair 2
	16	GND	GND
	17	GND	GND
	18	GND	GND
	19	DP_PWR	DisplayPort Power (+3.3V)
20	DP_AUX_SEL [1]	Auxiliary Selection	

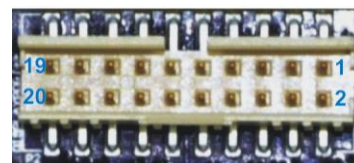

[1] – For **DP_AUX_SEL** – Cable assembly must tie high (+3.3V) for HDMI/DVI output and low (GND) for DisplayPort output.

HDMI / DVI / VGA

The *COM Express Type 10 Mini Carrier*'s DisplayPort++ connector can be used for display outputs other than DisplayPort. The use of HDMI, DVI or VGA can be done through a simple dongle or cable assembly like the ones shown below. These can be purchased from any OEM vendor (such as www.startech.com) or directly through Connect Tech. **Note: Some newer processor series like the Intel Baytrail can actually output proper TMDS signaling, so no external dongles are needed in this case. TMDS actually comes out directly from the module and carrier.**



LVDS Video Connector

The COM Express carrier provides dual 18 or 24 bit LVDS display channels via P4, which are connected directly from the COM Express module.

Function	LVDS Graphics																																																																		
Location	P9																																																																		
Carrier Connector PN	DF19G-20P-1H(54) - Manufacturer: Hirose																																																																		
Mating Connector PN	DF19-20S-1C - Manufacturer: Hirose																																																																		
Pinout	<table border="1"> <thead> <tr> <th>Pin</th> <th>Signal</th> <th>Description</th> </tr> </thead> <tbody> <tr> <td>1</td> <td>+3.3 VCC_PNL</td> <td>Panel Power</td> </tr> <tr> <td>2</td> <td>+3.3 VCC_PNL</td> <td>Panel Power</td> </tr> <tr> <td>3</td> <td>GND</td> <td>Digital ground</td> </tr> <tr> <td>4</td> <td>GND</td> <td>Digital ground</td> </tr> <tr> <td>5</td> <td>LVDS_A0_N</td> <td>Channel A Data</td> </tr> <tr> <td>6</td> <td>LVDS_A0_P</td> <td>Channel A Data</td> </tr> <tr> <td>7</td> <td>GND</td> <td>Digital ground</td> </tr> <tr> <td>8</td> <td>LVDS_A1_N</td> <td>Channel A Data</td> </tr> <tr> <td>9</td> <td>LVDS_A1_P</td> <td>Channel A Data</td> </tr> <tr> <td>10</td> <td>GND</td> <td>Digital ground</td> </tr> <tr> <td>11</td> <td>LVDS_A2_N</td> <td>Channel A Data</td> </tr> <tr> <td>12</td> <td>LVDS_A2_P</td> <td>Channel A Data</td> </tr> <tr> <td>13</td> <td>GND</td> <td>Digital ground</td> </tr> <tr> <td>14</td> <td>LVDS_CLK_N</td> <td>Channel A Data</td> </tr> <tr> <td>15</td> <td>LVDS_CLK_P</td> <td>Channel A Data</td> </tr> <tr> <td>16</td> <td>GND</td> <td>Digital ground</td> </tr> <tr> <td>17</td> <td>+5 VCC_PNL [1]</td> <td>Backlight Power</td> </tr> <tr> <td>18</td> <td>+5 VCC_PNL [1]</td> <td>Backlight Power</td> </tr> <tr> <td>19</td> <td>GND</td> <td>Digital ground</td> </tr> <tr> <td>20</td> <td>BKLT Control [2]</td> <td>LED ADJ</td> </tr> </tbody> </table>	Pin	Signal	Description	1	+3.3 VCC_PNL	Panel Power	2	+3.3 VCC_PNL	Panel Power	3	GND	Digital ground	4	GND	Digital ground	5	LVDS_A0_N	Channel A Data	6	LVDS_A0_P	Channel A Data	7	GND	Digital ground	8	LVDS_A1_N	Channel A Data	9	LVDS_A1_P	Channel A Data	10	GND	Digital ground	11	LVDS_A2_N	Channel A Data	12	LVDS_A2_P	Channel A Data	13	GND	Digital ground	14	LVDS_CLK_N	Channel A Data	15	LVDS_CLK_P	Channel A Data	16	GND	Digital ground	17	+5 VCC_PNL [1]	Backlight Power	18	+5 VCC_PNL [1]	Backlight Power	19	GND	Digital ground	20	BKLT Control [2]	LED ADJ			
	Pin	Signal	Description																																																																
	1	+3.3 VCC_PNL	Panel Power																																																																
	2	+3.3 VCC_PNL	Panel Power																																																																
	3	GND	Digital ground																																																																
	4	GND	Digital ground																																																																
	5	LVDS_A0_N	Channel A Data																																																																
	6	LVDS_A0_P	Channel A Data																																																																
	7	GND	Digital ground																																																																
	8	LVDS_A1_N	Channel A Data																																																																
	9	LVDS_A1_P	Channel A Data																																																																
	10	GND	Digital ground																																																																
	11	LVDS_A2_N	Channel A Data																																																																
	12	LVDS_A2_P	Channel A Data																																																																
	13	GND	Digital ground																																																																
	14	LVDS_CLK_N	Channel A Data																																																																
	15	LVDS_CLK_P	Channel A Data																																																																
	16	GND	Digital ground																																																																
	17	+5 VCC_PNL [1]	Backlight Power																																																																
	18	+5 VCC_PNL [1]	Backlight Power																																																																
19	GND	Digital ground																																																																	
20	BKLT Control [2]	LED ADJ																																																																	

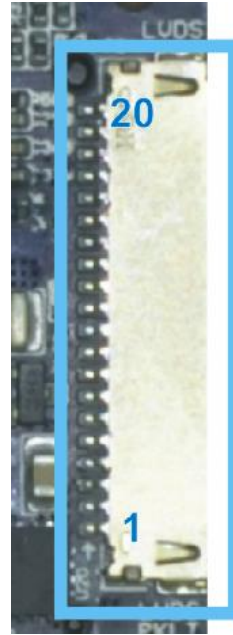

[1] – **+5V_VCC_PNL** – This voltage can be enabled or disabled to the display via Jumper J2 position C.

[2] – **BKLT Control** – This signal can be connected to the COM Express backlight control pin or to GND via Jumper J2 position D and E.

LVDS Backlight Power Connector

The *COM Express Type 10 Mini Carrier* carrier is equipped with a LVDS backlight inverter power supply connector. This power supply is designed to power HDA700LPT-GHL (or similar screen type) which has 13 parallel strings of 3 series white LEDs. Each white LED has a Vf of around 3.3V.

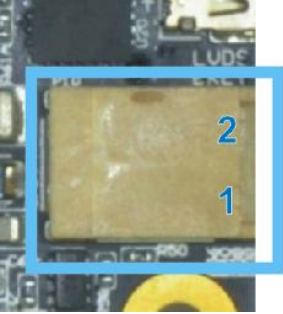
Function	LVDS backlight Inverter power							
Location	P10							
Carrier Connector PN	SM02B-BHSS-1-TB - Manufacturer: JST							
Mating Connector PN	BHSR-02VS-1 (N) - Manufacturer: JST							
Pinout	<table border="1"> <thead> <tr> <th>Pin</th> <th>Signal</th> </tr> </thead> <tbody> <tr> <td>1</td> <td>VA LED</td> </tr> <tr> <td>2</td> <td>VK LED</td> </tr> </tbody> </table>	Pin		Signal	1	VA LED	2	VK LED
Pin	Signal							
1	VA LED							
2	VK LED							

USB 2.0 Port Connectors

The *COM Express Type 10 Mini Carrier* has 6 external USB 2.0 ports. Each of these are directly sourced from the COM Express Type 10 module and do not go through any external hubs or bridges.

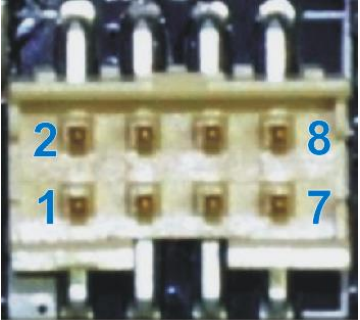
Function	USB 2.0																													
Locations	CCG010: P14A - A signals = Port1, B signals = Port2 P14B - A signals = Port3, B signals = Port4 P14C - A signals = Port5, B signals = Port6 CCG020: P14 - A signals = Port2, B signals = Port3																													
Carrier Connector PN	98424-G52-08LF - Manufacturer: FCI																													
Mating Connector PN	10073599-008LF - Manufacturer: FCI																													
Pinout	<table border="1"> <thead> <tr> <th>Pin</th> <th>Signal</th> <th>Description</th> </tr> </thead> <tbody> <tr> <td>1</td> <td>A-VBUS</td> <td>Port A Power (+5V)</td> </tr> <tr> <td>2</td> <td>B-VBUS [1]</td> <td>Port B Power (+5V)</td> </tr> <tr> <td>3</td> <td>A-D-</td> <td>Port A Data Pair</td> </tr> <tr> <td>4</td> <td>B-D-</td> <td>Port B Data Pair</td> </tr> <tr> <td>5</td> <td>A-D+</td> <td>Port A Data Pair</td> </tr> <tr> <td>6</td> <td>B-D+</td> <td>Port B Data Pair</td> </tr> <tr> <td>7</td> <td>A-GND</td> <td>Port A GND</td> </tr> <tr> <td>8</td> <td>B-GND</td> <td>Port B GND</td> </tr> </tbody> </table>	Pin	Signal		Description	1	A-VBUS	Port A Power (+5V)	2	B-VBUS [1]	Port B Power (+5V)	3	A-D-	Port A Data Pair	4	B-D-	Port B Data Pair	5	A-D+	Port A Data Pair	6	B-D+	Port B Data Pair	7	A-GND	Port A GND	8	B-GND	Port B GND	
Pin	Signal	Description																												
1	A-VBUS	Port A Power (+5V)																												
2	B-VBUS [1]	Port B Power (+5V)																												
3	A-D-	Port A Data Pair																												
4	B-D-	Port B Data Pair																												
5	A-D+	Port A Data Pair																												
6	B-D+	Port B Data Pair																												
7	A-GND	Port A GND																												
8	B-GND	Port B GND																												

[1] – **B-VBUS** – This voltage can be disable for USB Client mode on USB port 6, just installing jumper J2 position B.

USB 3.0/2.0 Port Connectors

The maximum configuration for a Type 10 COM Express Modules allows for 2 USB 3.0 Ports with integrated USB 2.0 Ports. However most modules currently on the market only expose a single USB 3.0 Port. The USB 3.0 signals are sourced from the COM Express Module, and run through a Pericom Semiconductor PI3EQX7502AIZDE re-driver.

Over current protection, power supply filtering and ESD protection is also provided.

Function	USB 2.0/3.0			
Location	P6			
Type	Intel USB 3.0 Internal 19-pin Connector http://www.intel.com/content/www/us/en/io/universal-serial-bus/usb3-internal-connector-cable-specification.html			
Carrier Connector PN	ABA-USB-152-K01 – Manufacturer: Lotes			
Mating Connector PN	Any USB 3.0 20-pin Internal Cable or Connector CTI PN: CBG131 PUB200-2611-01-00 – Manufacturer: ICT-Lanto			
Pinout	Pin	Description	Pin	Description
	1	Port A - VBUS	20	-
	2	Port A - SSRX-	19	Port B - VBUS
	3	Port A - SSRX+	18	Port B - SSRX-
	4	GND	17	Port B - SSRX+
	5	Port A - SSTX-	16	GND
	6	Port A - SSTX+	15	Port B - SSTX-
	7	GND	14	Port B - SSTX+
	8	Port A - D-	13	GND
	9	Port A - D+	12	Port B - D-
	10	-	11	Port B - D+

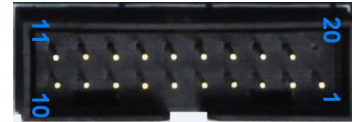

10/100/1000 Ethernet (GBE) Connector

The COM Express carrier features dual 10/100/1000 Ethernet Ports.

GBE Port 0 (P21B) is coming directly from the COM Express module.

GBE Port 1 (P21A) is coming from an Intel 82574 PCIe PHY Controller located on the carrier.

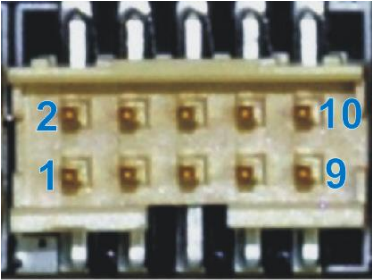
Function	LAN Connector																																			
Locations	P21A, P21B																																			
	98424-G52-10LF - Manufacturer: FCI																																			
Mating Connector PN	10073599-010LF - Manufacturer: FCI																																			
Pinout	<table border="1"> <thead> <tr> <th>Pin</th> <th>Signal</th> <th>Description</th> </tr> </thead> <tbody> <tr> <td>1</td> <td>MX1-</td> <td>Ethernet Pair 1</td> </tr> <tr> <td>2</td> <td>MX1+</td> <td>Ethernet Pair 1</td> </tr> <tr> <td>3</td> <td>MX2-</td> <td>Ethernet Pair 2</td> </tr> <tr> <td>4</td> <td>MX2+</td> <td>Ethernet Pair 2</td> </tr> <tr> <td>5</td> <td>SHELL</td> <td>RJ Shell Connection</td> </tr> <tr> <td>6</td> <td>SHELL</td> <td>RJ Shell Connection</td> </tr> <tr> <td>7</td> <td>MX3-</td> <td>Ethernet Pair 3</td> </tr> <tr> <td>8</td> <td>MX3+</td> <td>Ethernet Pair 3</td> </tr> <tr> <td>9</td> <td>MX4-</td> <td>Ethernet Pair 4</td> </tr> <tr> <td>10</td> <td>MX4+</td> <td>Ethernet Pair 4</td> </tr> </tbody> </table>	Pin	Signal		Description	1	MX1-	Ethernet Pair 1	2	MX1+	Ethernet Pair 1	3	MX2-	Ethernet Pair 2	4	MX2+	Ethernet Pair 2	5	SHELL	RJ Shell Connection	6	SHELL	RJ Shell Connection	7	MX3-	Ethernet Pair 3	8	MX3+	Ethernet Pair 3	9	MX4-	Ethernet Pair 4	10	MX4+	Ethernet Pair 4	
Pin	Signal	Description																																		
1	MX1-	Ethernet Pair 1																																		
2	MX1+	Ethernet Pair 1																																		
3	MX2-	Ethernet Pair 2																																		
4	MX2+	Ethernet Pair 2																																		
5	SHELL	RJ Shell Connection																																		
6	SHELL	RJ Shell Connection																																		
7	MX3-	Ethernet Pair 3																																		
8	MX3+	Ethernet Pair 3																																		
9	MX4-	Ethernet Pair 4																																		
10	MX4+	Ethernet Pair 4																																		

Software Support for the Intel 82574

Additional drivers will be needed to properly operate the GBE Port 1 on the COM Express carrier.

These drivers can be downloaded directly from Intel website from the below link:

<http://downloadcenter.intel.com/SearchResult.aspx?lang=eng&ProductFamily=Ethernet+Components&ProductLine=Ethernet+Controllers&Product=Intel%C2%AE+82574+Gigabit+Ethernet+Controller>

Audio Interface Connector

The COM Express Type 10 Mini Carrier features HD Audio capabilities care of the Cirrus Logic CS4207 Codec device. From the codec 1 input (microphone) and 1 output (headphone) are available.

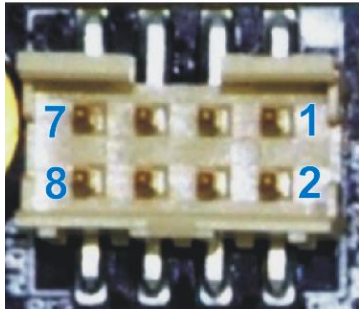
Function	Audio Connector																													
Locations	P13																													
Carrier Connector PN	98424-G52-10LF - Manufacturer: FCI																													
Mating Connector PN	10073599-010LF - Manufacturer: FCI																													
Pinout	<table border="1"> <thead> <tr> <th>Pin</th> <th>Signal</th> <th>Description</th> </tr> </thead> <tbody> <tr> <td>1</td> <td>-</td> <td>No Connect</td> </tr> <tr> <td>2</td> <td>-</td> <td>No Connect</td> </tr> <tr> <td>3</td> <td>MIC-R</td> <td>Mic Input - Right Channel</td> </tr> <tr> <td>4</td> <td>MIC-L</td> <td>Mic Input - Left Channel</td> </tr> <tr> <td>5</td> <td>GND</td> <td>Mic GND / Sheild</td> </tr> <tr> <td>6</td> <td>GND</td> <td>Headphone GND / Sheild</td> </tr> <tr> <td>7</td> <td>HPOUT-R</td> <td>Headphone Right Channel</td> </tr> <tr> <td>8</td> <td>HPOUT-L</td> <td>Headphone Left Channel</td> </tr> </tbody> </table>	Pin	Signal		Description	1	-	No Connect	2	-	No Connect	3	MIC-R	Mic Input - Right Channel	4	MIC-L	Mic Input - Left Channel	5	GND	Mic GND / Sheild	6	GND	Headphone GND / Sheild	7	HPOUT-R	Headphone Right Channel	8	HPOUT-L	Headphone Left Channel	
Pin	Signal	Description																												
1	-	No Connect																												
2	-	No Connect																												
3	MIC-R	Mic Input - Right Channel																												
4	MIC-L	Mic Input - Left Channel																												
5	GND	Mic GND / Sheild																												
6	GND	Headphone GND / Sheild																												
7	HPOUT-R	Headphone Right Channel																												
8	HPOUT-L	Headphone Left Channel																												

Software Support for the CS4207

The audio codec used on the carrier board is the CS4207 from Cirrus Logic.

Additional drivers will be needed to properly operate audio on the COM Express carrier. Some downloadable links can be found below.

Windows XP Driver: http://www.cirrus.com/en/pubs/software/CS4207_WinXP_1-0-0-38.zip

Windows 7/Vista Driver: http://www.cirrus.com/en/pubs/software/CS4207_WinVista_Win7_32-64-bit_6-6001-1-30.zip

Linux Driver: Included in kernels 2.6.30 and up.

External SATA (CCG010 Only)

The *COM Express Type 10 Mini Carrier* features two SATA connections. SATA port 0 is routed to the below external connector, where SATA 1 is routed to the mSATA slot.

Function	SATA host																	
Locations	P11																	
Carrier Connector PN	Industry standard vertical entry SATA host connector with locking capability																	
Mating Connector PN	Industry SATA cable with locking tab																	
Pinout	<table border="1"> <thead> <tr> <th>Pin</th> <th>Signal</th> </tr> </thead> <tbody> <tr> <td>1</td> <td>GND</td> </tr> <tr> <td>2</td> <td>SATA_TX_P</td> </tr> <tr> <td>3</td> <td>SATA_TX_N</td> </tr> <tr> <td>4</td> <td>GND</td> </tr> <tr> <td>5</td> <td>SATA_RX_N</td> </tr> <tr> <td>6</td> <td>SATA_RX_P</td> </tr> <tr> <td>7</td> <td>GND</td> </tr> </tbody> </table>			Pin	Signal	1	GND	2	SATA_TX_P	3	SATA_TX_N	4	GND	5	SATA_RX_N	6	SATA_RX_P	7
Pin	Signal																	
1	GND																	
2	SATA_TX_P																	
3	SATA_TX_N																	
4	GND																	
5	SATA_RX_N																	
6	SATA_RX_P																	
7	GND																	

mini PCIe & mSATA Slots

Dual Function mini PCIe mSATA Slots

The COM Express Type 10 Mini Carrier has a standard mini PCIe slot and a special dual purpose functionality mini PCIe / mSATA slots. The dual purpose slot can accept either a mini PCIe module or a mSATA SSD module. These slots have special circuitry that allows for the selection between connecting PCIe lanes or SATA lanes.

Each slot is also provided with a USB 2.0 connection in addition to the PCIe as per the mini PCIe specification; see below for a block diagram of the slots functionality.

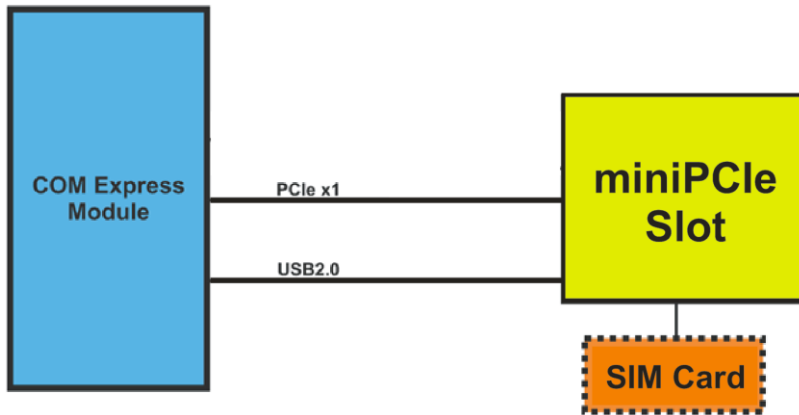

Standard mini PCIe Slot Block Diagram (U19)

Note: SIM card is only connected to the "left" mini pcie Slot 1

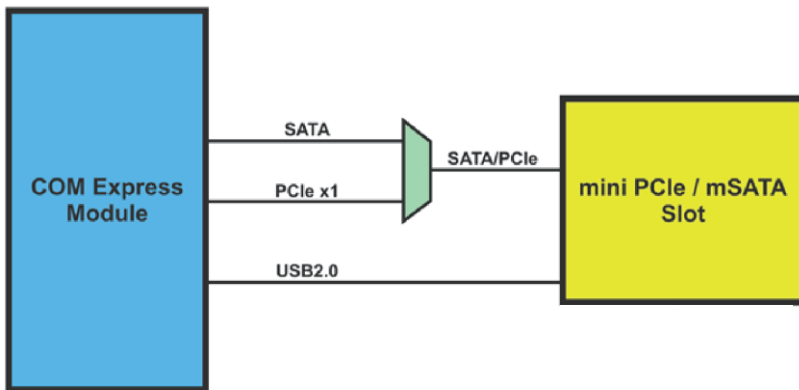

PCIe / SATA Dual Functionality Diagram (U12)

*** Selection between mSATA and mini pcie is done via Jumper J2 position F. (ON = mini pcie, OFF = mSATA)*

Half and Full Length mini PCIe / mSATA module Installation

The COM Express Type 10 Mini Carrier's mini pcie / mSATA slots are designed for easy ruggedized selection between full and half-length modules. This is done via the installation of M2.5 threaded standoffs. Standoffs and screws are provided with the shipping configuration of the carrier board. Below are some examples of how the various modules sizes can be installed.

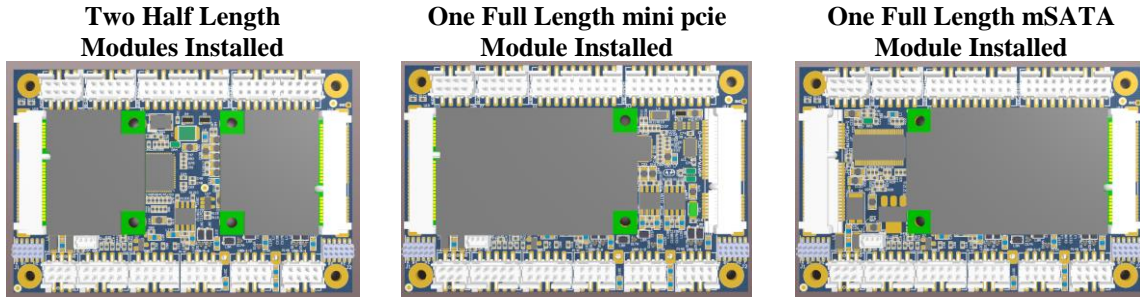

Standoff and Screw Assembly Details

Below is a diagram of how the standoffs and mounting hardware should be installed. If the screw mount type standoffs is not preferred a solder-in standoff is also available.

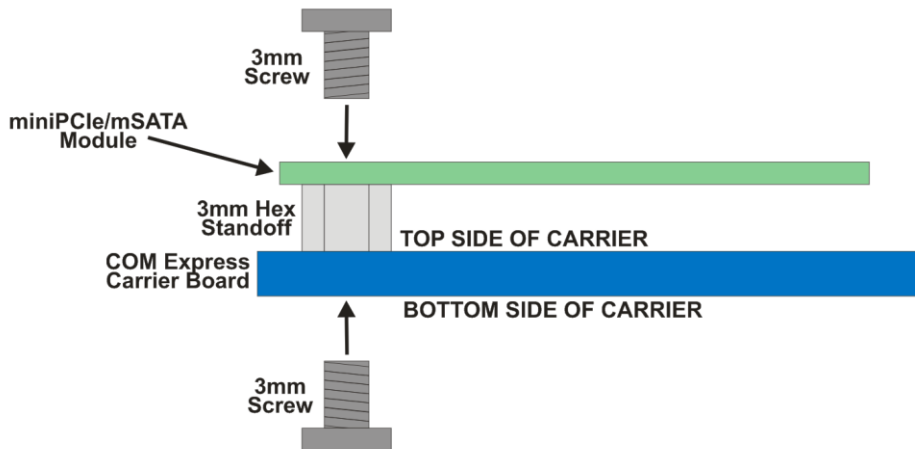

CCG020 – External Hard Drive Installation

The CCG020 model only has a single mSATA link, so if an external 2.5" (or other) drive is needed, this can be facilitated by the use of a mSATA to SATA adapter. Contact sales@connecttech.com for more details on this configuration.

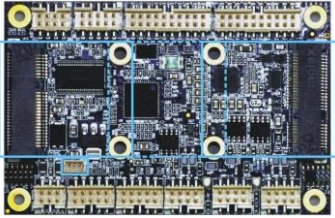

mini pcie / mSATA Connector Pinout

Function	mini PCIe / mSATA Slots																																																																																																																																																																																																																						
Locations	U19 (“left slot” mini pcie) U12 (“right slot” mini pcie/mSATA)																																																																																																																																																																																																																						
Carrier Connector PN	Standard 52-pin 0.8mm pitch PCI Express mini Card connector																																																																																																																																																																																																																						
Pinout	mSATA Pinout	mini pcie Pinout																																																																																																																																																																																																																					
	<table border="1"> <thead> <tr> <th>Pin Number</th> <th>Description</th> </tr> </thead> <tbody> <tr><td>1</td><td>NC</td></tr> <tr><td>2</td><td>+3.3V</td></tr> <tr><td>3</td><td>NC</td></tr> <tr><td>4</td><td>GND</td></tr> <tr><td>5</td><td>NC</td></tr> <tr><td>6</td><td>+1.5V</td></tr> <tr><td>7</td><td>NC</td></tr> <tr><td>8</td><td>NC</td></tr> <tr><td>9</td><td>GND</td></tr> <tr><td>10</td><td>NC</td></tr> <tr><td>11</td><td>NC</td></tr> <tr><td>12</td><td>NC</td></tr> <tr><td>13</td><td>NC</td></tr> <tr><td>14</td><td>NC</td></tr> <tr><td>15</td><td>GND</td></tr> <tr><td>16</td><td>NC</td></tr> <tr><td>17</td><td>NC</td></tr> <tr><td>18</td><td>GND</td></tr> <tr><td>19</td><td>NC</td></tr> <tr><td>20</td><td>NC</td></tr> <tr><td>21</td><td>RESV</td></tr> <tr><td>22</td><td>NC</td></tr> <tr><td>23</td><td>SATA TX+ To Host System</td></tr> <tr><td>24</td><td>+3.3V</td></tr> <tr><td>25</td><td>SATA TX- To Host System</td></tr> <tr><td>26</td><td>GND</td></tr> <tr><td>27</td><td>GND</td></tr> <tr><td>28</td><td>+1.5V</td></tr> <tr><td>29</td><td>GND</td></tr> <tr><td>30</td><td>NC</td></tr> <tr><td>31</td><td>SATA RX- From Host System</td></tr> <tr><td>32</td><td>NC</td></tr> <tr><td>33</td><td>SATA RX+ From Host System</td></tr> <tr><td>34</td><td>GND</td></tr> <tr><td>35</td><td>GND</td></tr> <tr><td>36</td><td>NC</td></tr> <tr><td>37</td><td>GND</td></tr> <tr><td>38</td><td>NC</td></tr> <tr><td>39</td><td>+3.3V</td></tr> <tr><td>40</td><td>GND</td></tr> <tr><td>41</td><td>+3.3V</td></tr> <tr><td>42</td><td>NC</td></tr> <tr><td>43</td><td>RESV</td></tr> <tr><td>44</td><td>NC</td></tr> <tr><td>45</td><td>NC</td></tr> <tr><td>46</td><td>NC</td></tr> <tr><td>47</td><td>NC</td></tr> <tr><td>48</td><td>+1.5V</td></tr> <tr><td>49</td><td>NC</td></tr> <tr><td>50</td><td>GND</td></tr> <tr><td>51</td><td>NC</td></tr> <tr><td>52</td><td>+3.3V</td></tr> </tbody> </table>	Pin Number	Description	1	NC	2	+3.3V	3	NC	4	GND	5	NC	6	+1.5V	7	NC	8	NC	9	GND	10	NC	11	NC	12	NC	13	NC	14	NC	15	GND	16	NC	17	NC	18	GND	19	NC	20	NC	21	RESV	22	NC	23	SATA TX+ To Host System	24	+3.3V	25	SATA TX- To Host System	26	GND	27	GND	28	+1.5V	29	GND	30	NC	31	SATA RX- From Host System	32	NC	33	SATA RX+ From Host System	34	GND	35	GND	36	NC	37	GND	38	NC	39	+3.3V	40	GND	41	+3.3V	42	NC	43	RESV	44	NC	45	NC	46	NC	47	NC	48	+1.5V	49	NC	50	GND	51	NC	52	+3.3V	<table border="1"> <thead> <tr> <th>Pin Number</th> <th>Description</th> </tr> </thead> <tbody> <tr><td>1</td><td>NC</td></tr> <tr><td>2</td><td>+3.3V</td></tr> <tr><td>3</td><td>NC</td></tr> <tr><td>4</td><td>GND</td></tr> <tr><td>5</td><td>NC</td></tr> <tr><td>6</td><td>+1.5V</td></tr> <tr><td>7</td><td>CLKREQ#</td></tr> <tr><td>8</td><td>UIM_PWR</td></tr> <tr><td>9</td><td>GND</td></tr> <tr><td>10</td><td>UIM_DATA</td></tr> <tr><td>11</td><td>PCIe CLK+</td></tr> <tr><td>12</td><td>UIM_CLK</td></tr> <tr><td>13</td><td>PCIe CLK-</td></tr> <tr><td>14</td><td>UIM_RESET</td></tr> <tr><td>15</td><td>GND</td></tr> <tr><td>16</td><td>UIM_VPP</td></tr> <tr><td>17</td><td>NC</td></tr> <tr><td>18</td><td>GND</td></tr> <tr><td>19</td><td>NC</td></tr> <tr><td>20</td><td>W_DISABLE#</td></tr> <tr><td>21</td><td>RESV</td></tr> <tr><td>22</td><td>NC</td></tr> <tr><td>23</td><td>PCIe RX+ To Host System</td></tr> <tr><td>24</td><td>+3.3V</td></tr> <tr><td>25</td><td>PCIe RX- To Host System</td></tr> <tr><td>26</td><td>GND</td></tr> <tr><td>27</td><td>GND</td></tr> <tr><td>28</td><td>+1.5V</td></tr> <tr><td>29</td><td>GND</td></tr> <tr><td>30</td><td>SMB_CLK</td></tr> <tr><td>31</td><td>PCIe TX- From Host System</td></tr> <tr><td>32</td><td>SMB_DATA</td></tr> <tr><td>33</td><td>PCIe TX+ From Host System</td></tr> <tr><td>34</td><td>GND</td></tr> <tr><td>35</td><td>GND</td></tr> <tr><td>36</td><td>USB D-</td></tr> <tr><td>37</td><td>GND</td></tr> <tr><td>38</td><td>USB D+</td></tr> <tr><td>39</td><td>+3.3V</td></tr> <tr><td>40</td><td>GND</td></tr> <tr><td>41</td><td>+3.3V</td></tr> <tr><td>42</td><td>NC</td></tr> <tr><td>43</td><td>RESV</td></tr> <tr><td>44</td><td>NC</td></tr> <tr><td>45</td><td>NC</td></tr> <tr><td>46</td><td>NC</td></tr> <tr><td>47</td><td>NC</td></tr> <tr><td>48</td><td>+1.5V</td></tr> <tr><td>49</td><td>NC</td></tr> <tr><td>50</td><td>GND</td></tr> <tr><td>51</td><td>NC</td></tr> <tr><td>52</td><td>+3.3V</td></tr> </tbody> </table>	Pin Number	Description	1	NC	2	+3.3V	3	NC	4	GND	5	NC	6	+1.5V	7	CLKREQ#	8	UIM_PWR	9	GND	10	UIM_DATA	11	PCIe CLK+	12	UIM_CLK	13	PCIe CLK-	14	UIM_RESET	15	GND	16	UIM_VPP	17	NC	18	GND	19	NC	20	W_DISABLE#	21	RESV	22	NC	23	PCIe RX+ To Host System	24	+3.3V	25	PCIe RX- To Host System	26	GND	27	GND	28	+1.5V	29	GND	30	SMB_CLK	31	PCIe TX- From Host System	32	SMB_DATA	33	PCIe TX+ From Host System	34	GND	35	GND	36	USB D-	37	GND	38	USB D+	39	+3.3V	40	GND	41	+3.3V	42	NC	43	RESV	44	NC	45	NC	46	NC	47	NC	48	+1.5V	49	NC	50	GND	51	NC	52	+3.3V	
Pin Number	Description																																																																																																																																																																																																																						
1	NC																																																																																																																																																																																																																						
2	+3.3V																																																																																																																																																																																																																						
3	NC																																																																																																																																																																																																																						
4	GND																																																																																																																																																																																																																						
5	NC																																																																																																																																																																																																																						
6	+1.5V																																																																																																																																																																																																																						
7	NC																																																																																																																																																																																																																						
8	NC																																																																																																																																																																																																																						
9	GND																																																																																																																																																																																																																						
10	NC																																																																																																																																																																																																																						
11	NC																																																																																																																																																																																																																						
12	NC																																																																																																																																																																																																																						
13	NC																																																																																																																																																																																																																						
14	NC																																																																																																																																																																																																																						
15	GND																																																																																																																																																																																																																						
16	NC																																																																																																																																																																																																																						
17	NC																																																																																																																																																																																																																						
18	GND																																																																																																																																																																																																																						
19	NC																																																																																																																																																																																																																						
20	NC																																																																																																																																																																																																																						
21	RESV																																																																																																																																																																																																																						
22	NC																																																																																																																																																																																																																						
23	SATA TX+ To Host System																																																																																																																																																																																																																						
24	+3.3V																																																																																																																																																																																																																						
25	SATA TX- To Host System																																																																																																																																																																																																																						
26	GND																																																																																																																																																																																																																						
27	GND																																																																																																																																																																																																																						
28	+1.5V																																																																																																																																																																																																																						
29	GND																																																																																																																																																																																																																						
30	NC																																																																																																																																																																																																																						
31	SATA RX- From Host System																																																																																																																																																																																																																						
32	NC																																																																																																																																																																																																																						
33	SATA RX+ From Host System																																																																																																																																																																																																																						
34	GND																																																																																																																																																																																																																						
35	GND																																																																																																																																																																																																																						
36	NC																																																																																																																																																																																																																						
37	GND																																																																																																																																																																																																																						
38	NC																																																																																																																																																																																																																						
39	+3.3V																																																																																																																																																																																																																						
40	GND																																																																																																																																																																																																																						
41	+3.3V																																																																																																																																																																																																																						
42	NC																																																																																																																																																																																																																						
43	RESV																																																																																																																																																																																																																						
44	NC																																																																																																																																																																																																																						
45	NC																																																																																																																																																																																																																						
46	NC																																																																																																																																																																																																																						
47	NC																																																																																																																																																																																																																						
48	+1.5V																																																																																																																																																																																																																						
49	NC																																																																																																																																																																																																																						
50	GND																																																																																																																																																																																																																						
51	NC																																																																																																																																																																																																																						
52	+3.3V																																																																																																																																																																																																																						
Pin Number	Description																																																																																																																																																																																																																						
1	NC																																																																																																																																																																																																																						
2	+3.3V																																																																																																																																																																																																																						
3	NC																																																																																																																																																																																																																						
4	GND																																																																																																																																																																																																																						
5	NC																																																																																																																																																																																																																						
6	+1.5V																																																																																																																																																																																																																						
7	CLKREQ#																																																																																																																																																																																																																						
8	UIM_PWR																																																																																																																																																																																																																						
9	GND																																																																																																																																																																																																																						
10	UIM_DATA																																																																																																																																																																																																																						
11	PCIe CLK+																																																																																																																																																																																																																						
12	UIM_CLK																																																																																																																																																																																																																						
13	PCIe CLK-																																																																																																																																																																																																																						
14	UIM_RESET																																																																																																																																																																																																																						
15	GND																																																																																																																																																																																																																						
16	UIM_VPP																																																																																																																																																																																																																						
17	NC																																																																																																																																																																																																																						
18	GND																																																																																																																																																																																																																						
19	NC																																																																																																																																																																																																																						
20	W_DISABLE#																																																																																																																																																																																																																						
21	RESV																																																																																																																																																																																																																						
22	NC																																																																																																																																																																																																																						
23	PCIe RX+ To Host System																																																																																																																																																																																																																						
24	+3.3V																																																																																																																																																																																																																						
25	PCIe RX- To Host System																																																																																																																																																																																																																						
26	GND																																																																																																																																																																																																																						
27	GND																																																																																																																																																																																																																						
28	+1.5V																																																																																																																																																																																																																						
29	GND																																																																																																																																																																																																																						
30	SMB_CLK																																																																																																																																																																																																																						
31	PCIe TX- From Host System																																																																																																																																																																																																																						
32	SMB_DATA																																																																																																																																																																																																																						
33	PCIe TX+ From Host System																																																																																																																																																																																																																						
34	GND																																																																																																																																																																																																																						
35	GND																																																																																																																																																																																																																						
36	USB D-																																																																																																																																																																																																																						
37	GND																																																																																																																																																																																																																						
38	USB D+																																																																																																																																																																																																																						
39	+3.3V																																																																																																																																																																																																																						
40	GND																																																																																																																																																																																																																						
41	+3.3V																																																																																																																																																																																																																						
42	NC																																																																																																																																																																																																																						
43	RESV																																																																																																																																																																																																																						
44	NC																																																																																																																																																																																																																						
45	NC																																																																																																																																																																																																																						
46	NC																																																																																																																																																																																																																						
47	NC																																																																																																																																																																																																																						
48	+1.5V																																																																																																																																																																																																																						
49	NC																																																																																																																																																																																																																						
50	GND																																																																																																																																																																																																																						
51	NC																																																																																																																																																																																																																						
52	+3.3V																																																																																																																																																																																																																						

Asynchronous Serial RS-232/485 Connector

The *COM Express Type 10 Mini Carrier* provides 2 asynchronous serial ports. Each of these ports are derived directly from the COM Express Type 10 SER1 and SER2 connections. These ports are hardware selectable through the means of jumpers to RS-232 or RS-422/485

RS-232/485 Connector

Function	RS-232 / RS-485		
Locations	P7		
Carrier Connector PN	98424-G52-10LF - Manufacturer: FCI		
Mating Connector PN	10073599-010LF - Manufacturer: FCI		
Pinout	Pin	Signal	Description
	1	232TX0/485TX0+	RS-232 0 Transmit / RS-485 0 Transmit +
	2	232RX0/485RX0+	RS-232 0 Transmit / RS-485 0 Transmit +
	3	485TX0-	RS-485 0 Transmit -
	4	485RX0-	RS-485 0 Transmit -
	5	232/485-GND0	Port 0 Ground
	6	232/485-GND1	Port 1 Ground
	7	232TX1/485TX1+	RS-232 1 Transmit / RS-485 1 Transmit +
	8	232RX1/485RX+	RS-232 1 Transmit / RS-485 1 Transmit +
	9	485TX1-	RS-485 1 Transmit -
	10	485RX1+	RS-485 1 Receive -

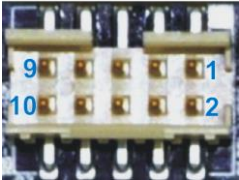

RS-232/485 Jumper Configuration

Below is a listing of the 3 main configurations of jumper settings for the serial ports on the carrier board. Positions A & B set the line mode, while positions C – F set BIAS termination for RS-485 signaling. See the complete listing of all jumper settings on the carrier in the Carrier Board Jumper Settings section of this manual.

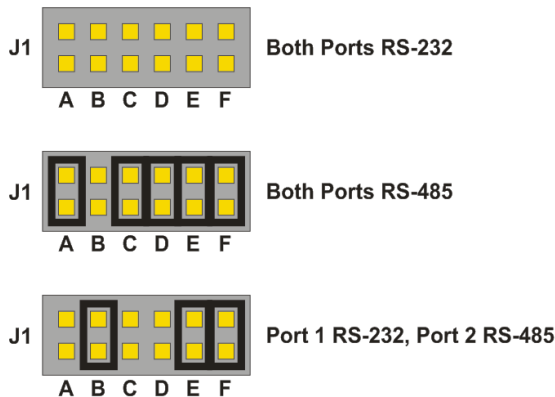

microSD Card Connector

The *COM Express Type 10 Mini Carrier* provides a Micro SD Card Slot at P4. This Micro SD Card slot sources the SDIO interface from the COM Express modules GPIO pins.

**** Note this SD card slot will ONLY operate if the COM Express module provides the SDIO interface over the GPIO pins. Some COM Express modules may have this as a BIOS setting, others will be strictly a hardware option. See below for the SDIO / GPIO mapping ****

Function	Micro SD Card Slot		
Locations	P3		
Carrier Connector PN	502570-0893 - Manufacturer: Molex		
Pinout	Pin	SDIO Signal	COM Express GPIO Mapping
	1	SD_D2	GPI2
	2	SD_D3	GPI3
	3	SD_CMD	GPO1
	4	SD_VCC (+3.3V)	-
	5	SD_CLK	GPO0
	6	GND	-
	7	SD_D0	GPI0
	8	SD_D1	GPI1
	9	GND	-
	10	SD_CD#	GP03



Misc/System Connector

This system control header can be used to connect power button, reset button, PC speaker, I2C device and monitor other power rails.

Function	Misc/System Control Header		
Location	P19		
Carrier Connector PN	98424-G52-20LF - Manufacturer: FCI		
Mating Connector PN	10073599-020LF - Manufacturer: FCI		
Pinout	Pin	Signal	Description
	1	PWRM.PWRBTN#	Power Button
	2	GND	Ground
	3	PWRM.SYS_RESET#	Reset Button
	4	GND	Ground
	5	PWRM.SUS_S3#	S3 Power Status Output
	6	SMB.ALERT#	SMB Alert Signal
	7	RESET-OUT	Carrier Board Reset Output
	8	SMB.DAT	SMB Data
	9	GPO0	GPIO Output Bit-0
	10	SMB.CK	SMB Clock
	11	GPO1	GPIO Output Bit-1
	12	PWRM.BATLOW#	Battery Low Indicator
	13	GPO2	GPIO Output Bit-2
	14	I2C.CK	I2C Clock
	15	GPO3	GPIO Output Bit-3
	16	I2C.DAT	I2C Data
	17	GPI0	GPIO Input Bit-0
	18	GPI2	GPIO Input Bit-2
	19	GPI1	GPIO Input Bit-1
20	GPI3	GPIO Input Bit-3	

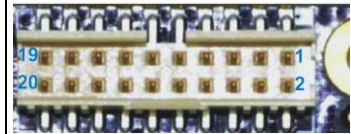

RTC Battery Connector

The COM Express Type 10 Mini Carrier allows for an external RTC battery to be connected. This battery should be a 3V DC battery, and it will hold all BIOS settings including date and time. Some COM Express modules may have the RTC battery on the module so in this case this connector can be left disconnected.

Connect Tech provides a Battery with cable assembly in any of the “Full” or “Starter” cable kits, please see the [Cable Section](#) of this manual for more details.

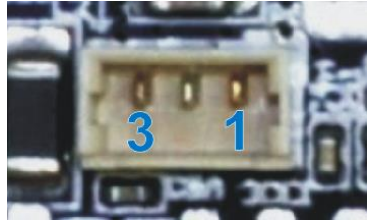
Function	RTC Battery Connector														
Location	P5														
Battery Voltage	+3V DC														
Carrier Connector PN	53047-0310 - Manufacturer: Molex														
Mating Connector PN	51021-0300 - Manufacturer: Molex														
Pinout	<table border="1"> <thead> <tr> <th>Pin</th> <th>Signal</th> <th>Description</th> </tr> </thead> <tbody> <tr> <td>1</td> <td>+3V</td> <td>RTC Battery Voltage Input</td> </tr> <tr> <td>2</td> <td>NC</td> <td>No Connect</td> </tr> <tr> <td>3</td> <td>GND</td> <td>Ground / Return</td> </tr> </tbody> </table>				Pin	Signal	Description	1	+3V	RTC Battery Voltage Input	2	NC	No Connect	3	GND
Pin	Signal	Description													
1	+3V	RTC Battery Voltage Input													
2	NC	No Connect													
3	GND	Ground / Return													

Typical Hardware Installation Procedure

1. Ensure all external system power supplies are off.
2. Install the COM Express module. Be sure to follow the manufacturer’s direction for proper heatsink/heatspreader installation and any other cooling instructions from the manufacturer.
3. Install the necessary cables for the application. At a minimum, this would include:
 - a) Power cable to the input power connector
 - b) Connect a video display cable
 - c) Keyboard and mouse via USB
 - d) SATA Hard Drive
4. Connect the power cable to power supply
5. Ensure your power supply is in the range of +6V to +14V DC
6. Switch on the power supply

On-board Indicator LEDs (CCG010 Only)

The COM Express Type 10 Mini Carrier has 10 on-board indicator LEDs.

LED	Description
D13	HDD Activity
D2B	GBE1 Link
D2B	GBE1 Activity
D1B	GBE0 Link
D1B	GBE0 Activity
D10	+VIN Power ON
D11	+5V Power ON
D12	+3.3V Power ON
D8	+1.5V Power ON
D9	+1.8V Power ON

See below for a diagram of where these LEDs are located.

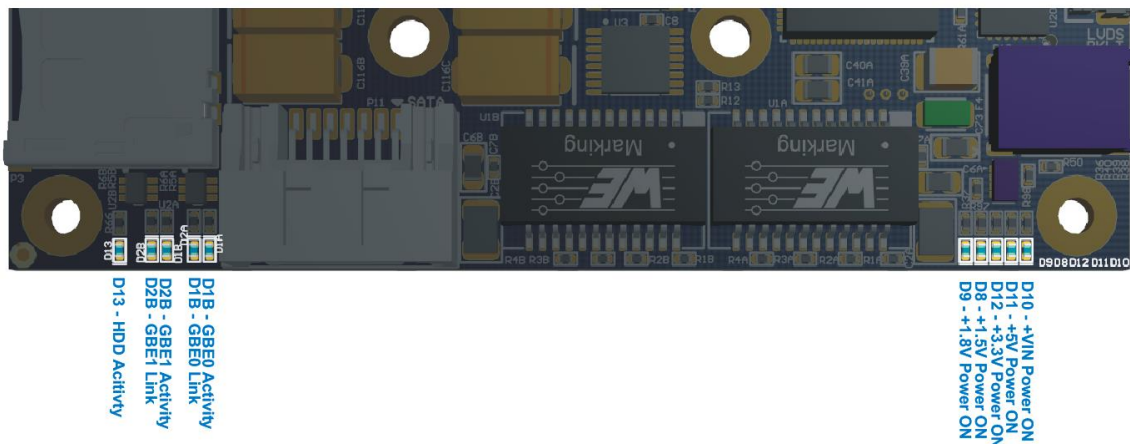

Jumper Settings

The COM Express Type 10 Mini Carrier has two jumper blocks, J1 to control the serial ports and J2 for system settings such as SD/GPIO, LVDS and mSATA/miniPCIe selection.

J1 – RS-232/485 Jumper Block

Position	Jumper Description
A	Serial Mode Bit - M0
B	Serial Mode Bit – M1
C	LVDS Panel
D	Port 0 RS-485 BIAS-
E	Port 1 RS-485 BIAS+
F	Port 1 RS-485 BIAS-

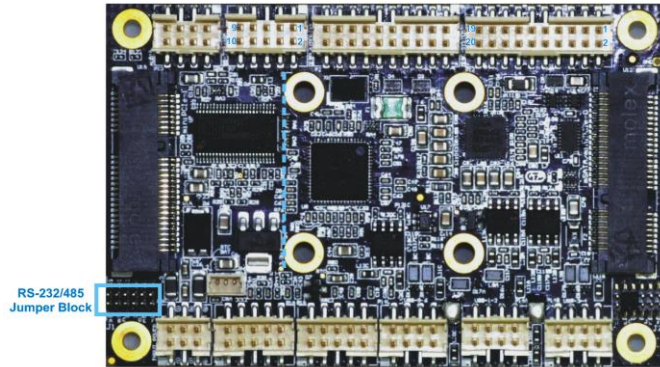

Serial Line Modes

Position A – M0	Position B – M1	Port 0 Selected Mode	Port 1 Selected Mode
OFF	OFF	RS-232	RS-232
OFF	ON	RS-422/485	RS-422/485
ON	OFF	RS-232	RS-422/485
ON	ON	Undefined	Undefined

J2 – System Jumper Block

Position	Jumper Description
A	SD Card (ON) / GPIO (OFF) selection
B	USB Port 7 Client Enable
C	Enable +5V Backlight Supply to P9
D	Connect LVDS PWM Signal to GND
E	Connect LVDS PWM to COM Express
F	mini PCIe (ON) / mSATA (OFF) selection

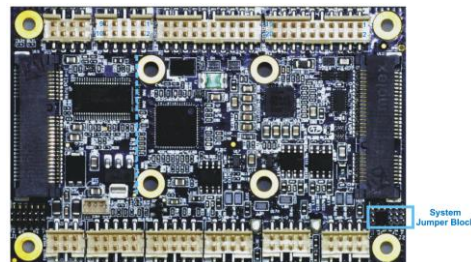

Current Consumption Details

Below are some examples of actual measurements taken with the *COM Express Type 10 Mini Carrier* running in various test setups. Some values will change depending on what COM Express module is installed, please refer to the module manufactures manual for full details on the current consumption of the particular module you are using.

Actual Measurements	Amps	Watts
Carrier standalone no module installed, powered ON, with no loads	0.14	1.68
Module Installed ^[1] , single DDI video output, USB keyboard with system sitting in BIOS	0.72	8.64
Module Installed ^[1] , single DDI video output, all peripherals connected, booted Linux running, CPU running stress test	1.03	12.36

Note [1] : *COM Express Type 10 Module used for measurements - Intel Core N2600 CPU*

Thermal Details

All components on the *COM Express Type 10 Mini Carrier* are rated to a maximum operating temperature of -40°C to +85°C. The carrier has been fully tested to run in both extremes in an environmental test chamber with 125 CFM of airflow.

Below are some thermal images of the carrier running standalone at room temperature with and without a module installed.

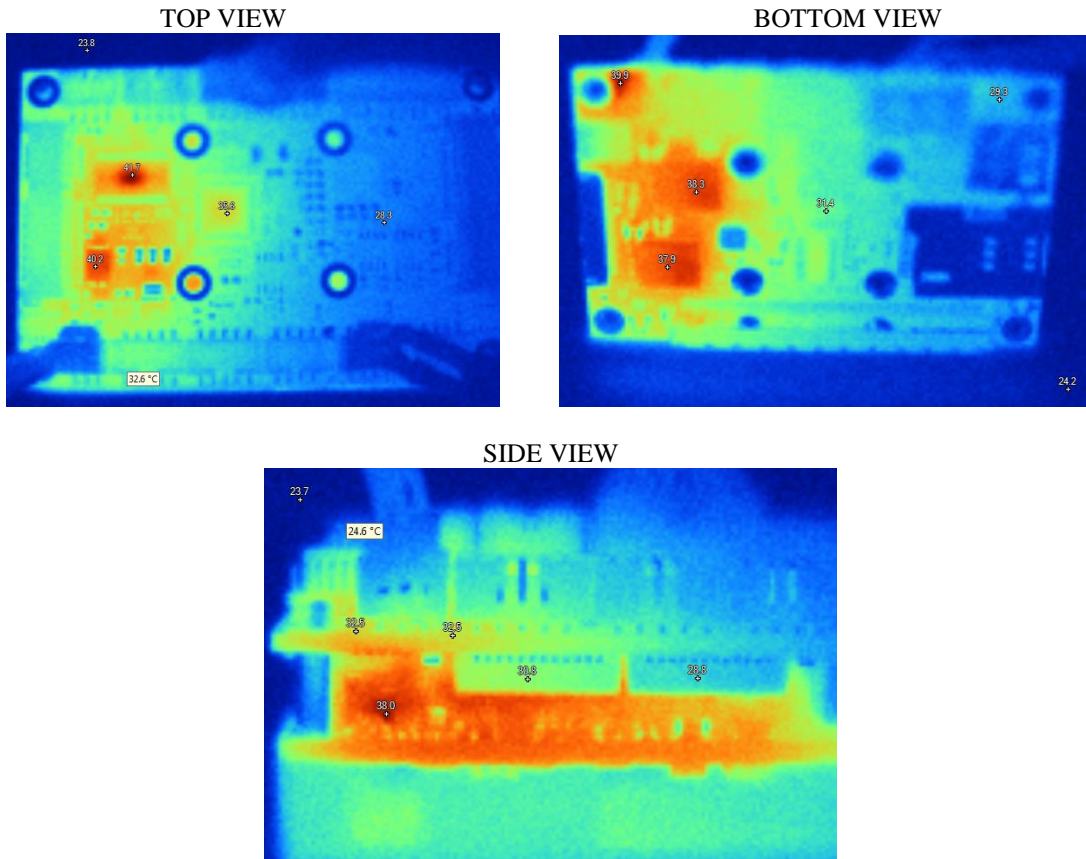

Mechanical Details

A complete 3D STEP Model file of carrier board can be downloaded here:

http://www.connecttech.com/ftp/3d_models/CCG010-20_3D_MODEL.zip

2D Mechanical Dimensioned Drawing (CCG010) – All dimensions are shown in (mm)

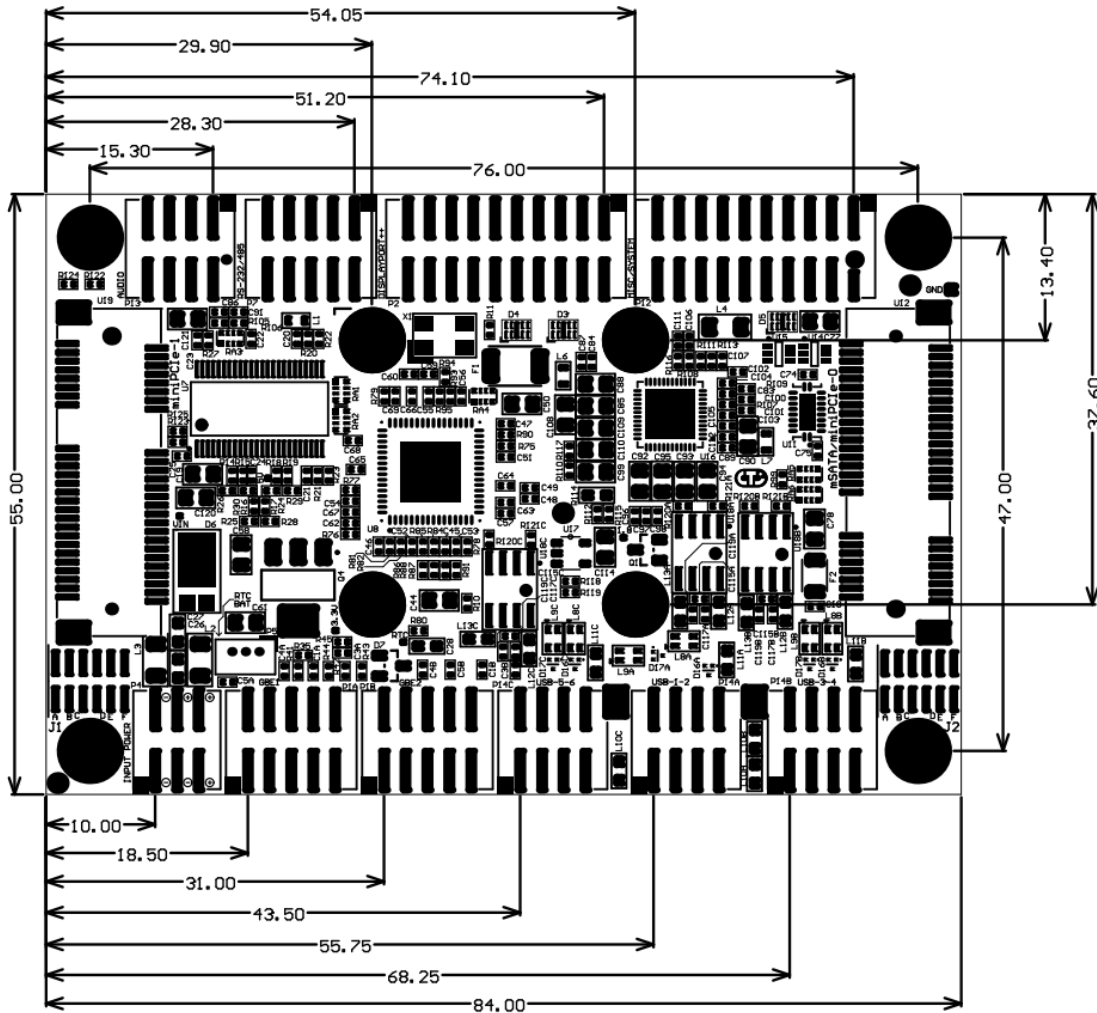

2D Mechanical Dimensioned Drawing (CCG020) – All dimensions are shown in (mm)

Drawing By Request– support@connecttech.com

Cables and Cable Kit Information

Cable Kits

The following tables summarize the COM Express carrier’s available cable kits from Connect Tech. These cable kits all include 200mm length breakout cables to PC type panel mountable connectors. These cables can be used for production deployment or for lab bring-up and test purposes.

CCG010 Cable Kit - CKG014 – “Full” Cable Kit

Description	Part Number	Quantity
Dual USB 2.0 panel mount to 8-pin MiniTek w/Latch	CBG104	3
Dual DB-9 panel mount to 10-pin MiniTek w/Latch	CBG111	1
Power Cable - Unterminated wires to 6-pin MiniTek w/Latch	CBG112	1
DisplayPort++ panel mount to 20-pin MiniTek w/Latch	CBG113	1
RJ-45 panel mount to 10-pin MiniTek w/Latch	CBG117	2
Dual 3.5mm Stereo Audio panel mount to 8-pin MiniTek w/Latch	CBG118	1
System Cable - Unterminated wires to 20-pin MiniTek w/Latch	CBG116	1

CCG010 Cable Kit - CKG015 – “Starter” Cable Kit

Description	Part Number	Quantity
Dual USB 2.0 panel mount to 8-pin MiniTek w/Latch	CBG104	1
Power Cable - Unterminated wires to 6-pin MiniTek w/Latch	CBG112	1
DisplayPort++ panel mount to 20-pin MiniTek w/Latch	CBG113	1
RJ-45 panel mount to 10-pin MiniTek w/Latch	CBG117	1
System Cable - Unterminated wires to 20-pin MiniTek w/Latch	CBG116	1

CCG020 Cable Kit - CKG039 – “Full” Cable Kit

Description	Part Number	Quantity
Dual USB 2.0 panel mount to 8-pin MiniTek w/Latch	CBG104	3
Dual DB-9 panel mount to 10-pin MiniTek w/Latch	CBG111	1
Power Cable - Unterminated wires to 6-pin MiniTek w/Latch	CBG112	1
DisplayPort++ panel mount to 20-pin MiniTek w/Latch	CBG113	1
RJ-45 panel mount to 10-pin MiniTek w/Latch	CBG117	2
Dual 3.5mm Stereo Audio panel mount to 8-pin MiniTek w/Latch	CBG118	1
System Cable - Unterminated wires to 20-pin MiniTek w/Latch	CBG116	1
Dual USB 3.0 Cable - OEM	CBG131	1

CCG020 Cable Kit - CKG040 – “Starter” Cable Kit

Description	Part Number	Quantity
Dual USB 2.0 panel mount to 8-pin MiniTek w/Latch	CBG104	1
Power Cable - Unterminated wires to 6-pin MiniTek w/Latch	CBG112	1
DisplayPort++ panel mount to 20-pin MiniTek w/Latch	CBG113	1
RJ-45 panel mount to 10-pin MiniTek w/Latch	CBG117	1
System Cable - Unterminated wires to 20-pin MiniTek w/Latch	CBG116	1
Dual USB 3.0 Cable - OEM	CBG131	1

Detailed Cable Information

RJ-45 panel mount to 10-pin MiniTek w/Latch - CBG117



RJ45 (8P8C)	Signal	10-pin MiniTek
2	MX1-	1
1	MX1+	2
6	MX2-	3
3	MX2+	4
SHELL	SHELL	5
SHELL	SHELL	6
5	MX3-	7
4	MX3+	8
8	MX4-	9
7	MX4+	10

Dual 3.5mm Stereo Audio panel mount to 8-pin MiniTek w/Latch - CBG118



Dual 3.5mm Audio Jacks	Signal	8-pin MiniTek
-	-	1
-	-	2
Jack1 - Ring	MIC-R	3
Jack1 - Tip	MIC-L	4
Jack1 - Sleeve	GND	5
Jack2 - Sleeve	GND	6
Jack2 - Ring	HPOUT-R	7
Jack2 - Tip	HPOUT-L	8

Dual USB 2.0 panel mount to 8-pin MiniTek w/Latch - CBG104



USB #1	Signal	8-pin MiniTek
1	VCC	1
2	D-	3
3	D+	5
4	GND	7
USB #2		
1	VCC	2
2	D-	4
3	D+	6
4	GND	8

DisplayPort++ panel mount to 20-pin MiniTek w/Latch - CBG113



DisplayPort++	Signal	20-pin MiniTek
1	DP0+	1
10	DP3+	2
3	DP0-	3
12	DP3-	4
2	GND	5
5	GND	6
4	DP1+	7
17	DPAUX-	8
6	DP1-	9
15	DPAUX+	10
8	GND	11
11	GND	12
7	DP2+	13
18	DP.HPD	14
9	DP2-	15
16	GND	16
16	GND	17
19	GND	18
20	DP_PWR	19
13	DP_AUX_SEL	20

Dual DB-9 panel mount to 10-pin MiniTek w/Latch - CBG111

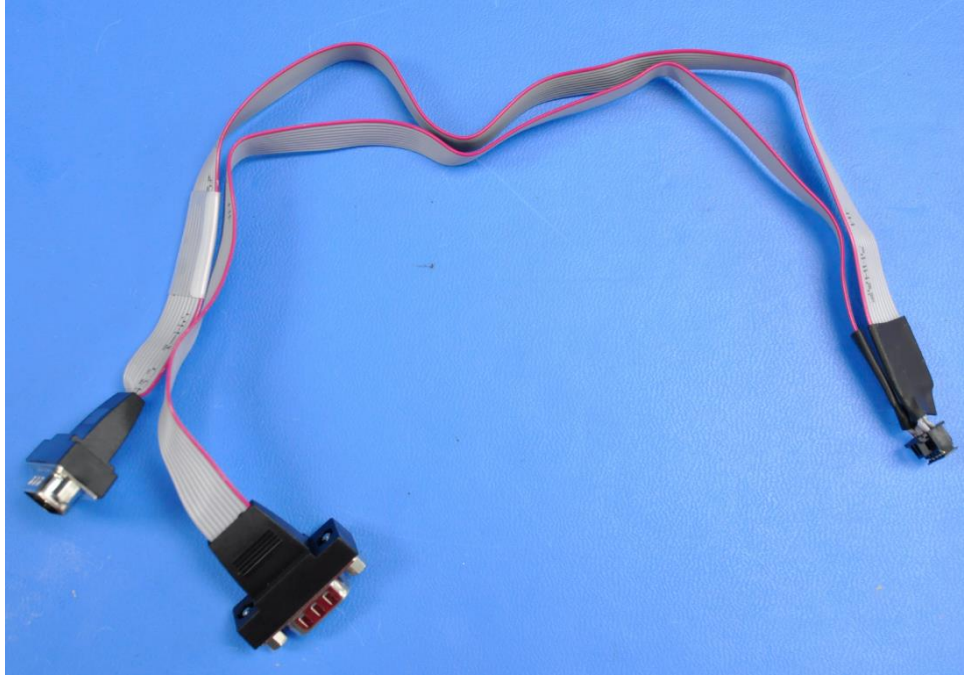

DB9-0	Signal	10-pin MiniTek
3	TX0/TX0+	1
2	RX0/RX0+	2
4	TX0-	3
1	RX0-	4
5	GND0	5
DB9-1	Signal	
5	GND1	6
3	TX1/TX1+	7
2	RX1/RX+	8
4	TX1-	9
1	RX1+	10

3V CR2032 RTC Battery with 3-pin Connector and Cable Assembly - 6032101013

Note: Battery may not be exactly as shown. This RTC battery ships with every shipment.

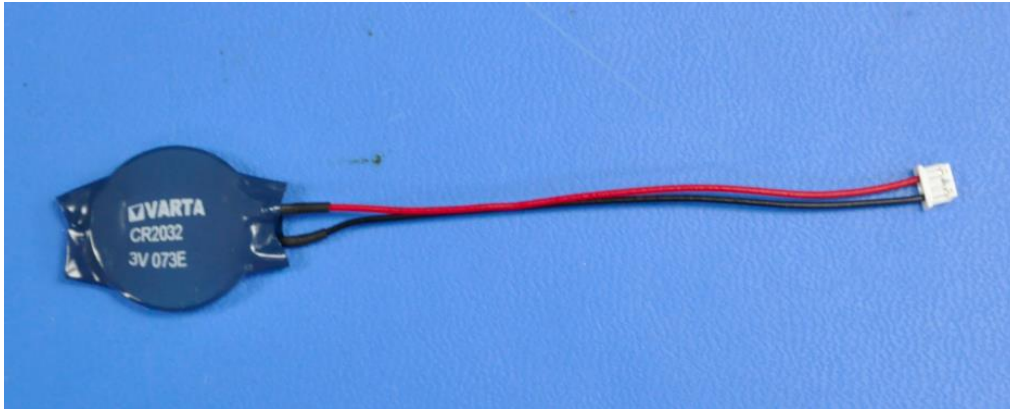

CR2032 Battery	Signal	3-pin MiniTek
Positive Terminal	+3V	1
-	NC	2
Negative Terminal	GND	3

System Cable - Unterminated wires to 20-pin MiniTek w/Latch - CBG116

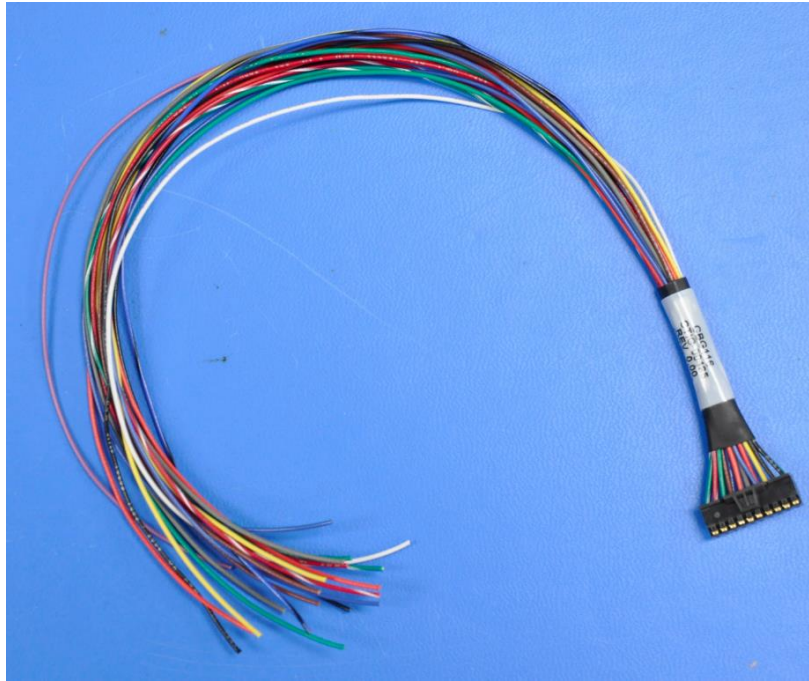

Unterminated Wires	Signal	Color	20-pin MiniTek
-	PWRM.PWRBTN#	green	1
-	GND	BLACK	2
-	PWRM.SYS_RESET#	white	3
-	GND	BLACK	4
-	PWRM.SUS_S3#	red	5
-	SMB.ALERT#	yellow/silver	6
-	RESET-OUT	orange/silver	7
-	SMB.DAT	blue/silver	8
-	GPO0	brown	9
-	SMB.CK	grey/silver	10
-	GPO1	yellow	11
-	PWRM.BATLOW#	orange	12
-	GPO2	blue	13
-	I2C.CK	brown	14
-	GPO3	grey	15
-	I2C.DAT	green	16
-	GPI0	purple	17
-	GPI2	red/white	18
-	GPI1	blue/black	19
-	GPI3	green/white	20

Power Cable - Unterminated wires to 6-pin MiniTek w/Latch - CBG112



Unterminated Wires	Signal	Color	6-pin MiniTek
-	GND	BLACK	1
-	GND	BLACK	2
-	GND	BLACK	3
-	+12V	YELLOW	4
-	+12V	YELLOW	5
-	+12V	YELLOW	6

CBG131 - Dual USB 3.0 to 20-Pin Cable

The CBG131 cable is an OEM 19-pin internal type cable, to panel mountable USB 3.0 Type-A Connector(s).

Hardware	
Cable Jacket Type	PVC - Polyvinyl Chloride
Cable Shield Type	Aluminum-Mylar Foil with Braid
Connector(s)	
Connector A	2 - USB 3.0 A (9 pin; SuperSpeed) Female
Connector B	1 - IDC (20 pin; USB 3.0; Motherboard Header) Female
Physical Characteristics	
Color	Blue
Wire Gauge	28 AWG
Cable Length	1.6 ft [0.5 m]
Product Length	19.7 in [500 mm]
Product Width	1.4 in [36.5 mm]
Product Height	0.5 in [12 mm]
Product Weight	2.5 oz [70 g]



Note: Cable will not ship with bracket